

SIEMENS



TC65 Terminal Siemens Cellular Engine

Version: 02.000
DocID: TC65 Terminal_HD_V02.000

Hardware Interface Description

Document Name: **TC65 Terminal Hardware Interface Description**

Version: **02.000**

Date: **August 21, 2006**

DocId: **TC65 Terminal_HD_V02.000**

Status: **Confidential / Released**

General Notes

Product is deemed accepted by Recipient and is provided without interface to Recipient's products. The documentation and/or Product are provided for testing, evaluation, integration and information purposes. The documentation and/or Product are provided on an "as is" basis only and may contain deficiencies or inadequacies. The Documentation and/or Product are provided without warranty of any kind, express or implied. To the maximum extent permitted by applicable law, Siemens further disclaims all warranties, including without limitation any implied warranties of merchantability, completeness, fitness for a particular purpose and non-infringement of third-party rights. The entire risk arising out of the use or performance of the Product and documentation remains with Recipient. This Product is not intended for use in life support appliances, devices or systems where a malfunction of the product can reasonably be expected to result in personal injury. Applications incorporating the described product must be designed to be in accordance with the technical specifications provided in these guidelines. Failure to comply with any of the required procedures can result in malfunctions or serious discrepancies in results. Furthermore, all safety instructions regarding the use of mobile technical systems, including GSM products, which also apply to cellular phones must be followed. Siemens or its suppliers shall, regardless of any legal theory upon which the claim is based, not be liable for any consequential, incidental, direct, indirect, punitive or other damages whatsoever (including, without limitation, damages for loss of business profits, business interruption, loss of business information or data, or other pecuniary loss) arising out the use of or inability to use the Documentation and/or Product, even if Siemens has been advised of the possibility of such damages. The foregoing limitations of liability shall not apply in case of mandatory liability, e.g. under the German Product Liability Act, in case of intent, gross negligence, injury of life, body or health, or breach of a condition which goes to the root of the contract. However, Claims for Damages arising from a breach of a condition which goes to the root of the contract shall be limited to the foreseeable damage which is intrinsic to the contract, unless caused by intent or gross negligence or based on liability for injury of life, body or health. The above provision does not imply a change on the burden of proof to the detriment of the Recipient. Subject to change without notice at any time. The interpretation of this general note shall be governed and construed according to German law without reference to any other substantive law.

Copyright

Copying of this document and giving it to others and the use or communication of the contents thereof, are forbidden without express authority. Offenders are liable to the payment of damages. All rights reserved in the event of grant of a patent or the registration of a utility model or design.

Copyright © Siemens AG 2006

Contents

0	Document History	6
1	Introduction	7
1.1	Related Documents.....	7
1.2	Terms and Abbreviations	8
1.3	Type Approval.....	11
1.4	Safety Precautions	13
2	Key Features of the TC65 Terminal.....	15
2.1	Technical Requirements for Using TC65 Terminal.....	18
3	Interface Description	19
3.1	Overview	19
3.2	Block Diagram.....	20
3.3	Operating Modes	21
3.4	Terminal Circuit.....	22
3.5	Power Supply.....	23
3.5.1	Switch on TC65 Terminal	24
3.5.2	Reset TC65 Terminal	24
3.5.3	Switch off TC65 Terminal	24
3.5.4	Disconnecting Power Supply	24
3.5.5	Signal States after Startup.....	25
3.6	RS-232 Interface.....	26
3.7	Audio Interface.....	28
3.7.1	Supported Audio Modes	29
3.7.2	Speech Processing.....	30
3.8	Antenna Interface.....	31
3.9	SIM Interface.....	31
3.10	IO Interface	33
3.10.1	GPIOs	35
3.10.2	Using GPIO Pin10 as Pulse Counter	36
3.10.3	I ² C Interface	36
3.10.4	SPI Interface	37
3.10.5	Analog-to Digital Converter (ADC).....	39
3.10.6	RTC Backup Supply	40
3.10.7	Power Supply	40
3.10.8	VDD Supply	40
3.10.9	ON/OFF Switch	40
3.11	Status LED.....	41
4	Mechanical Characteristics	42
4.1	IO Interface Connector.....	44
4.1.1	Recommended Mating Connector	45
5	Electrical and Environmental Characteristics.....	46
5.1	Characteristics of the Power Supply.....	49
5.2	Characteristics of On/Off control	50
5.3	Characteristics of the RS-232 interface.....	51
5.4	Characteristics of the SIM Interface for Use with 3V Cards.....	51
5.5	Characteristics of the SIM interface for Use with 1.8V Cards	52
5.6	Characteristics of the Audio Interface	53
5.6.1	Audio Parameters Adjustable by AT Commands.....	54

5.7	Characteristics of the GPIOs.....	55
5.8	Characteristics of the Pulse Counter	55
5.9	Characteristics of the I ² C interface	56
5.10	Characteristics of the SPI interface	56
5.11	Characteristics of the ADC Interface	57
5.12	Characteristics of the RTC Supply	57
5.13	RF Connector.....	58
6	Full Type Approval	59
6.1	Siemens Reference Setup	59
6.2	Compliance with FCC Rules and Regulations	60
6.3	Cable Requirements	60
6.4	Restrictions	61
6.5	CE Conformity.....	61
6.6	Electromagnetic Compatibility (EMC).....	61
7	List of Parts and Recommended Accessories	62

Tables

Table 1:	Directives.....	11
Table 2:	Standards of North American Type Approval.....	11
Table 3:	Standards of European Type Approval.....	12
Table 4:	Requirements of quality.....	12
Table 5:	Overview of operating modes	21
Table 6:	Pin assignment of the Western plug for power supply	23
Table 7:	Signal states.....	25
Table 8:	9-pole D-Sub (female) RS-232	26
Table 9:	Audio modes	29
Table 10:	Pin assignment – SIM card holder.....	32
Table 11:	Assignment of the IO interface connector.....	34
Table 12:	I ² C interface – signal description	36
Table 13:	SPI interface – signal description	37
Table 14:	ADC signal description	39
Table 15:	RTC signal description	40
Table 16:	Mechanical characteristics.....	42
Table 17:	Electrical and mechanical characteristics of the Micro Mate-N-LOK connector.....	44
Table 18:	Ordering information for mating connector Tyco Micro Mate-N-LOK	45
Table 19:	Absolute maximum ratings	46
Table 20:	Operating conditions.....	47
Table 21:	Highest temperatures	47
Table 22:	Longest duration until 81°C are reached	48
Table 23:	Longest duration when GPRS Class Change does not work properly	48
Table 24:	Characteristics of the power supply	49
Table 25:	Characteristics On/Off control	50
Table 26:	Characteristics of the RS-232 interface	51
Table 27:	Characteristics of the SIM interface for use with 3V cards.....	51
Table 28:	Characteristics of the SIM interface for use with 1.8V cards.....	52
Table 29:	Characteristics of the audio interface	53
Table 30:	Audio Parameters Adjustable by AT Commands.....	54
Table 31:	Characteristics of the GPIOs	55
Table 32:	Characteristics of the pulse counter	55
Table 33:	Characteristics of the I2C interface.....	56
Table 34:	Characteristics of the SPI interface	56
Table 35:	Characteristics of the ADC interface.....	57

Table 36: Characteristics of the RTC supply	57
Table 37: RF connector	58
Table 38: List of parts and accessories	62

Figures

Figure 1: TC65 Terminal front view	19
Figure 2: TC65 Terminal rear view	19
Figure 3: Block diagram	20
Figure 4: TC65 Terminal circuit block diagram	22
Figure 5: Female 6-pole Western plug for power supply, ignition, emergency off.....	23
Figure 6: Pin assignment RS-232 (D-Sub 9-pole female).....	26
Figure 7: Audio Western plug (4-pole female).....	28
Figure 8: Audio block diagram.....	28
Figure 9: Pin location of the Molex SIM card holder and position	31
Figure 10: IO interface connector front view.....	33
Figure 11: Location of GPIO pins	35
Figure 12: Characteristics of SPI modes	38
Figure 13: ADC balanced amplifier.....	39
Figure 14: Mechanical dimensions	43
Figure 15: Tyco Micro Mate-N-LOK series on the TC65 Terminal	44
Figure 16: Mating connector Tyco Micro Mate-N-LOK series	44
Figure 17: Receptacle contact for Tyco Micro Mate-N-LOK series	44
Figure 18: Mechanical dimensions of the Tyco Mate_N_LOK connector on the TC65 Terminal	45
Figure 19: Reference equipment for approval	59

0 Document History

Preceding document: "TC65 Terminal Hardware Interface Description" Version 01.041
New document: "TC65 Terminal Hardware Interface Description" Version **02.000**

Chapter	What is new
1.3	Added automotive directive and CE logo. Updated list of standards.
2	Updated audio features.
3.5.5	New chapter Signal States after Startup
3.10; 3.10.1	Corrected description of IO interface connector pin 7 and pin 8. Added remark on connecting pull-up or pull-down resistors to all GPIO pins used as output.
3.10.6	Removed possibility to backup RTC from a chargeable external battery.
5.1	Changed unit for current consumption in Power Down Mode from μA to mA.
5.6	Modified MICP, MICN characteristics.
5.12	Table 36: Modified RTC input voltage values (RTC backup).

Preceding document: "TC65 Terminal Hardware Interface Description" Version 01.030
New document: "TC65 Terminal Hardware Interface Description" Version 01.041

Chapter	What is new
Throughout manual	Changed release number; no further changes

1 Introduction

This document describes the hardware of the Siemens TC65 Terminal.

The scope of this document includes interface specifications, electrical issues and mechanical characteristics of TC65 Terminal. It specifies standards pertaining to wireless applications and outlines requirements that must be adhered to for successful product design. The TC65 Terminal is a compact GSM modem for the transfer of data, voice, SMS and faxes in GSM networks. Industrial standard interfaces and an integrated SIM card reader allow using TC65 Terminal easily as a quad band GSM terminal.

1.1 Related Documents

- [1] TC65 AT Command Set 02.000
- [2] TC65 Release Notes 02.000
- [3] Application Note 16: Upgrading TC65 Firmware
- [4] Multiplexer User's Guide
- [5] Multiplex Driver Developer's Guide for Windows 2000 and Windows XP
- [6] Multiplexer Driver Installation Guide for Windows 2000 and Windows XP
- [7] TC65 JAVA User's Guide
- [8] Java doc \wtk\doc\html\index.html
- [9] Application Note 24: Application Developer's Guide

Prior to using the GSM engine read the latest product information provided in the Release Notes.

You can use the following link to visit the Siemens Website:

<http://www.siemens.com/wm>

1.2 Terms and Abbreviations

Abbreviation	Description
ADC	Analog-to-Digital Converter
ANSI	American National Standards Institute
ARP	Antenna Reference Point
B	Thermistor Constant
BER	Bit Error Rate
BTS	Base Transceiver Station
CE	Conformité Européene (European Conformity)
CHAP	Challenge Handshake Authentication Protocol
CS	Coding Scheme
CSD	Circuit Switched Data
CTS	Clear to Send
DAC	Digital-to-Analog Converter
dBm0	Digital level, 3.14dBm0 corresponds to full scale, see ITU G.711, A-law
DCE	Data Communication Equipment (typically modems, e.g. Siemens GSM engine)
DCS 1800	Digital Cellular System, also referred to as PCN
DSP	Digital Signal Processor
DSR	Data Set Ready
DTE	Data Terminal Equipment (typically computer, terminal, printer or, for example, GSM application)
DTR	Data Terminal Ready
DTX	Discontinuous Transmission
EFR	Enhanced Full Rate
EGSM	Enhanced GSM
EMC	Electromagnetic Compatibility
ESD	Electrostatic Discharge
ETS	European Telecommunication Standard
FCC	Federal Communications Commission (U.S.)
FR	Full Rate
GMSK	Gaussian Minimum Shift Keying
GPIO	General Purpose Input/Output
GPRS	General Packet Radio Service
GSM	Global Standard for Mobile Communications

Abbreviation	Description
HiZ	High Impedance
HR	Half Rate
I/O	Input/Output
IMEI	International Mobile Equipment Identity
ISO	International Standards Organization
ITU	International Telecommunications Union
kbps	kbits per second
LED	Light Emitting Diode
Mbps	Mbits per second
MMI	Man Machine Interface
MO	Mobile Originated
MS	Mobile Station (GSM module), also referred to as TE
MT	Mobile Terminated
NTC	Negative Temperature Coefficient
PAP	Password Authentication Protocol
PBCCH	Packet Switched Broadcast Control Channel
PCB	Printed Circuit Board
PCM	Pulse Code Modulation
PCN	Personal Communications Network, also referred to as DCS 1800
PCS	Personal Communication System, also referred to as GSM 1900
PDU	Protocol Data Unit
PPP	Point-to-point protocol
PSU	Power Supply Unit
R&TTE	Radio and Telecommunication Terminal Equipment
RAM	Random Access Memory
RF	Radio Frequency
RTC	Real Time Clock
RTS	Request to Send
Rx	Receive Direction
SELV	Safety Extra Low Voltage
SIM	Subscriber Identification Module
SMS	Short Message Service
SPI	Serial Peripheral Interface
SRAM	Static Random Access Memory

Abbreviation	Description
TE	Terminal Equipment, also referred to as DTE
Tx	Transmit Direction
UART	Universal asynchronous receiver-transmitter
URC	Unsolicited Result Code
USSD	Unstructured Supplementary Service Data

1.3 Type Approval

TC65 Terminal is designed to comply with the directives and standards listed below.

Table 1: Directives

99/05/EC	“Directive of the European Parliament and of the Council of 9 March, 1999 on radio equipment and telecommunications terminal equipment and the mutual recognition of their conformity”, in short referred to as R&TTE Directive 1999/5/EC The product is labeled with the CE conformity mark CE 0682
89/336/EC	Directive on electromagnetic compatibility
73/23/EC	Directive on electrical equipment designed for use within certain voltage limits (Low Voltage Directive)
2002/95/EC	Directive of the European Parliament and of the Council of 27 January 2003 on the restriction of the use of certain hazardous substances in electrical and electronic equipment (RoHS) 
2002/96/EC	Directive of the European Parliament and of the Council on waste electrical and electronic equipment (WEEE)
2003/108/EC	Directive of the European Parliament and of the Council of 8 December 2003 amending directive 2002/96/ec on waste electrical and electronic equipment (WEEE)
ECE-R10	Directive on automotive EMC.

Table 2: Standards of North American Type Approval

CFR Title 47	“Code of Federal Regulations, Part 22 and Part 24 (Telecommunications, PCS)”; US Equipment Authorization FCC
NAPRD.03	“Overview of PCS Type certification review board Mobile Equipment Type Certification and IMEI control” PCS Type Certification Review board (PTCRB), Version 3.5.1
RSS133 (Issue2)	Canadian Standard

Table 3: Standards of European Type Approval

3GPP TS 51.010-1	“Digital cellular telecommunications system (Phase 2); Mobile Station (MS) conformance specification” V5.10.0
ETSI EN 301 511	“V9.0.2 (2003-03) Candidate Harmonized European Standard (Telecommunications series) Global System for Mobile communications (GSM); Harmonized standard for mobile stations in the GSM 900 and DCS 1800 bands covering essential requirements under article 3.2 of the R&TTE directive (1999/5/EC) (GSM 13.11 version 7.0.1 Release 1998)”
GCF-CC	“Global Certification Forum - Certification Criteria” V3.20
ETSI EN 301 489-1	“V1.4.1 Candidate Harmonized European Standard (Telecommunications series) Electro Magnetic Compatibility and Radio spectrum Matters (ERM); Electro Magnetic Compatibility (EMC) standard for radio equipment and services; Part 1: Common Technical Requirements”
ETSI EN 301 489-7	“V1.2.1 (2002-09) Candidate Harmonized European Standard (Telecommunications series) Electro Magnetic Compatibility and Radio spectrum Matters (ERM); Electro Magnetic Compatibility (EMC) standard for radio equipment and services; Part 7: Specific conditions for mobile and portable radio and ancillary equipment of digital cellular radio telecommunications systems (GSM and DCS)”
EN 60 950-1	Safety of information technology equipment (2001)

Table 4: Requirements of quality

IEC 60068	Environmental testing
DIN EN 60529	IP codes

1.4 Safety Precautions

The following safety precautions must be observed during all phases of the operation, usage, service or repair of any cellular terminal or mobile incorporating TC65 Terminal. Manufacturers of the cellular terminal are advised to convey the following safety information to users and operating personnel and incorporate these guidelines into all manuals supplied with the product. Failure to comply with these precautions violates safety standards of design, manufacture and intended use of the product. Siemens AG assumes no liability for customer's failure to comply with these precautions.



When in hospitals or other health care facilities, observe the restrictions on the use of mobiles. Switch off the cellular terminal or mobile if to be instructed to do so by the guidelines posted in sensitive areas. Medical equipment may be sensitive to RF energy.

The operation of cardiac pacemakers, other implanted medical equipment and hearing aids can be affected by interference from cellular terminals or mobiles placed close to the device. If in doubt about potential danger, contact the physician or the manufacturer of the device to verify that the equipment is properly shielded. Pacemaker patients are advised to keep their hand-held mobile away from the pacemaker, while it is on. This personal subgroup always should check the distance to the mobile.



Switch off the cellular terminal or mobile before boarding an aircraft. Make sure it cannot be switched on inadvertently. The operation of wireless appliances in an aircraft is forbidden to prevent interference with communications systems. Failure to observe these instructions may lead to the suspension or denial of cellular services to the offender, legal action, or both.

Check the local and actual laws about these themes.



Do not operate the cellular terminal or mobile in the presence of flammable gases or fumes. Switch off the cellular terminal when you are near petrol stations, fuel depots, chemical plants or where blasting operations are in progress. Operation of any electrical equipment in potentially explosive atmospheres can constitute a safety hazard.



Your cellular terminal or mobile receives and transmits radio frequency energy while switched on. Remember that interference can occur if it is used close to TV sets, radios, computers or inadequately shielded equipment. Follow any special regulations and always switch off the cellular terminal or mobile wherever forbidden, or when you suspect that it may cause interference or danger.



Road safety comes first! Do not use a hand-held cellular terminal or mobile while driving a vehicle unless it is securely mounted in a holder for speakerphone operation. Before making a call with a hand-held terminal or mobile park the vehicle.

Speakerphones must be installed by qualified personnel. Faulty installation or operation can constitute a safety hazard.

Check the actual and local laws about these themes.



IMPORTANT!

Cellular terminals or mobiles operate using radio signals and cellular networks. In that case connections cannot be guaranteed at all times under all conditions. Therefore, you should never rely solely upon any wireless device for essential communications, for example emergency calls.

Remember, in order to make calls or receive calls the cellular terminal or mobile must be switched on in a service area with adequate cellular signal strength.

Some networks do not allow for emergency calls if certain network services or phone features are in use (e.g. lock functions, fixed dialing etc.). You may need to deactivate those features before you can make an emergency call.

Some networks require a valid SIM card to be properly inserted in the cellular terminal or mobile.



If a power supply unit is used to supply the device it must meet the demands placed on SELV circuits in accordance with EN60950. The maximum permissible connection length between the device and the supply source should not exceed 3m.



According to the guidelines for human exposure to radio frequency energy, an antenna connected to the SMA jack of the device should be placed at least 20cm away from human bodies.

2 Key Features of the TC65 Terminal

Feature	Implementation
General	
Incorporates module	TC65 The TC65 module handles all processing for audio, signal and data within the TC65 Terminal. Internal software runs the application interface and the whole GSM protocol stack.
Frequency bands	Quad band: GSM 850/900/1800/1900MHz
GSM class	Small MS
Output power (according Release 99, V5)	to Class 4 (+33dBm ±2dB) for EGSM850 Class 4 (+33dBm ±2dB) for EGSM900 Class 1 (+30dBm ±2dB) for GSM1800 Class 1 (+30dBm ±2dB) for GSM1900 The values stated above are maximum limits. According to Release 99, Version 5, the maximum output power in a multislot configuration may be lower. The nominal reduction of maximum output power varies with the number of uplink timeslots used and amounts to 3.0dB for 2Tx, 4.8dB for 3Tx and 6.0dB for 4Tx.
Power supply	Single supply voltage 8V to 30V
Operating temperature	-30°C to +65°C ambient temperature
Physical	Dimensions: 130mm x 90mm x 38mm Weight: approx. 190g
RoHS, WEEE	All hardware components are fully compliant with the EU RoHS and WEEE Directives
GSM / GPRS features	
Data transfer	GPRS <ul style="list-style-type: none"> • Multislot Class 12 • Full PBCCH support • Mobile Station Class B • Coding Scheme 1 – 4 CSD <ul style="list-style-type: none"> • V.110, RLP, non-transparent • 2.4, 4.8, 9.6, 14.4kbps • USSD PPP-stack for GPRS data transfer

Feature	Implementation
SMS	<ul style="list-style-type: none"> • Point-to-point MT and MO • Cell broadcast • Text and PDU mode • Storage: SIM card plus 25 SMS locations in mobile equipment • Transmission of SMS alternatively over CSD or GPRS. Preferred mode can be user defined.
Fax	Group 3; Class 1
Audio	<p>Speech codecs:</p> <ul style="list-style-type: none"> • Half rate HR (ETS 06.20) • Full rate FR (ETS 06.10) • Enhanced full rate EFR (ETS 06.50/06.60/06.80) • Adaptive Multi Rate AMR <p>Line echo cancellation, DTMF, 7 ringing tones</p>
Software	
AT commands	AT-Hayes GSM 07.05 and 07.07, Siemens AT commands for RIL compatibility (NDIS/RIL)
Microsoft™ compatibility	RIL / NDIS for Pocket PC and Smartphone
Java platform JDK Version: 1.4.2_09	<p>Java Virtual Machine with APIs for AT Parser, Serial Interface, FlashFileSystem and TCP/IP Stack.</p> <p>Major benefits: seamless integration into Java applications, ease of programming, no need for application microcontroller, extremely cost-efficient hardware and software design – ideal platform for industrial GSM applications.</p> <p>The memory space available for Java programs is around 1.7 MB in the flash file system and around 400k RAM. Application code and data share the space in the flash file system and in RAM.</p>
SIM Application Toolkit	SAT Release 99
TCP/IP stack	Access by AT commands
IP address	IP version 6
Remote SIM Access	<p>TC65 Terminal supports Remote SIM Access. RSA enables TC65 Terminal to use a remote SIM card via its serial interface and an external application, in addition to the SIM card locally attached to the dedicated lines of the application interface. The connection between the external application and the remote SIM card can be a Bluetooth wireless link or a serial link.</p> <p>The necessary protocols and procedures are implemented according to the “SIM Access Profile Interoperability Specification of the Bluetooth Special Interest Group” (SAP).</p>
Firmware update	Upgradeable via serial interface.

Feature	Implementation
Interfaces	
Serial interface	<ul style="list-style-type: none"> 8-wire modem interface with status and control lines, unbalanced, asynchronous Fixed bit rates: 300 bps to 460,800 bps Autobauding: 1,200 bps to 460,800 bps Supports RTS0/CTS0 hardware handshake and software XON/XOFF flow control. Multiplex ability according to GSM 07.10 Multiplexer Protocol.
I ² C	I ² C bus for transmission rates up to 400kbps. Programmable with AT [^] SSPI command. Alternatively all pins of the I ² C interface are configurable as SPI.
SPI	Serial Peripheral Interface for transmission rates up to 6.5 Mbps. Programmable with AT [^] SSPI command. The I ² C interface is not available by using the SPI interface.
Audio	Analog (Microphone, Earpiece)
SIM interface	Supported SIM cards: 3V, 1.8V
Antenna	Connected via antenna SMA connector
Power on/off, Reset	
Power-on	Switch on via On/Off push button, ONOFF line on IO interface connector, DTR line at RS232 interface or IGT_IN line at power connector (available with recommended power supply)
Power-off	<ul style="list-style-type: none"> Normal switch-off by AT[^]SMSO or On/Off push button Emergency switch-off via EMERGOFF line at power connector Automatic switch-off in case of critical temperature and voltage conditions
Reset	Orderly shutdown and reset by AT command
Special features	
Real time clock	Timer functions via AT commands
GPIO	10 I/O pins of the application interface are programmable as GPIO. Programming is done via AT commands. Alternatively, GPIO pin 10 is configurable as pulse counter.
Pulse counter	Pulse counter for measuring pulse rates from 0 to 1000 pulses/sec. If the pulse counter is active the GPIO pin 10 is not available.
ADC inputs	Analog-to-Digital Converter with two balanced analog inputs for measuring external voltages.
Phonebook	SIM and phone

2.1 Technical Requirements for Using TC65 Terminal

- Computer running Windows 2000, Windows XP
- 1.8V or 3.0V SIM card
- 8 to 30 Volts power supply unit
- RS-232 cable (for high data rates $\leq 1.5\text{m}$)
- UART capable of data rates up to 460800 bps. Usually this requires an appropriate serial adapter to be installed on the computer.
- RF antenna
- Audio handset
- Customized mating connector for the IO interface connector type Micro Mate-N-LOK.
- Terminal program to control the COM port, for example Windows HyperTerminal.
- Access to a GSM/GPRS network providing support of the authentication protocol PAP, CHAP or MS-CHAP. The GPRS settings of your service provider should be at hand. Please contact your service provider or follow the link below to obtain all required information.

<http://www.gsmworld.com/technology/gprs/operators.shtml>

3 Interface Description

3.1 Overview

TC65 Terminal provides the following connectors for power supply, interface and antenna:

1. 24-pole GPIO Micro Mate-N-LOK connector for GPIOs, I²C, SPI, ADC
2. 9-pole (female) SUB-D plug for RS-232 serial interface
3. SMA connector (female) for antenna
4. On/Off push button
5. 4-pole Western plug (female) for audio accessory, such as a handset
6. SIM card holder
7. 6-pole Western plug (female) for power supply, ignition, power down signal

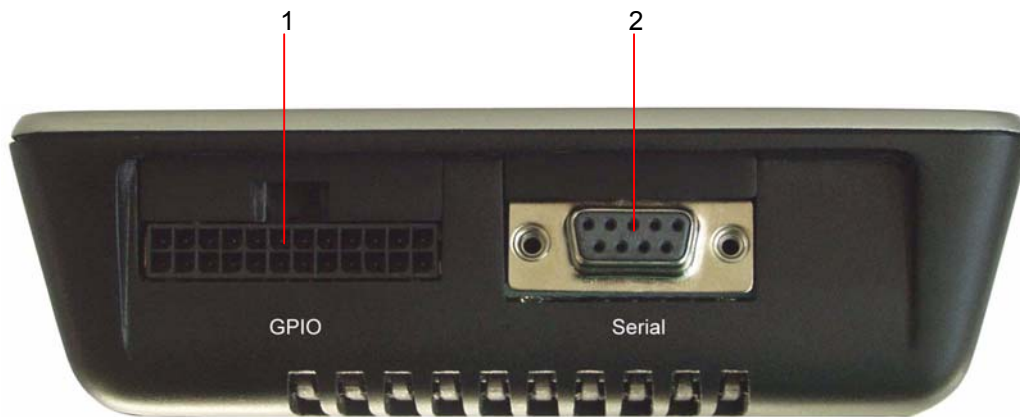

Figure 1: TC65 Terminal front view

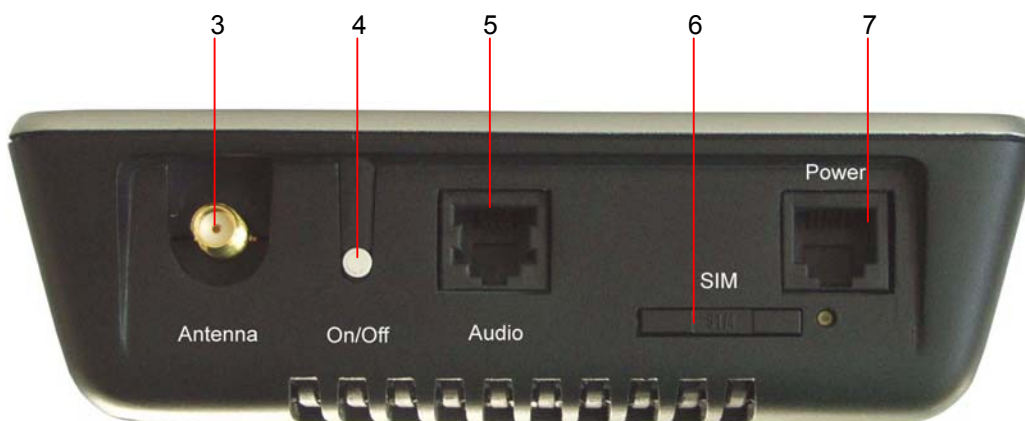
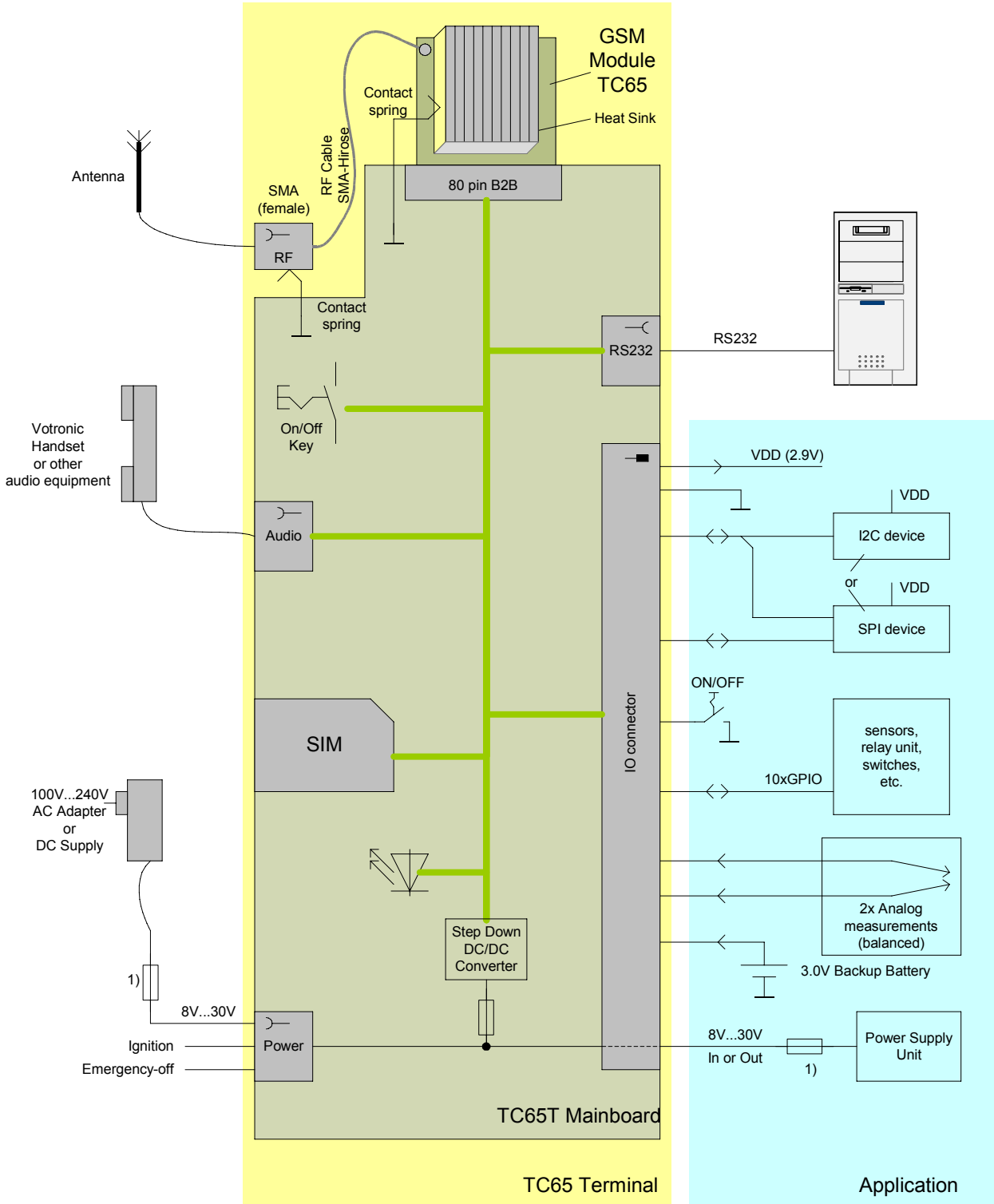

Figure 2: TC65 Terminal rear view

3.2 Block Diagram

Figure 3 shows a block diagram of a sample configuration that incorporates a TC65 Terminal and typical accessories.



1) Fast acting fuse $I \geq 0.8A$, (0.8...1.5 A²s) is recommended for 24V vehicle supply only.

Figure 3: Block diagram

3.3 Operating Modes

The table below briefly summarizes the various operating modes referred to in the following chapters.

Table 5: Overview of operating modes

Normal operation	GSM / GPRS SLEEP	Various power save modes set with AT+CFUN command. Software is active to minimum extent. If the Terminal was registered to the GSM network in IDLE mode, it is registered and paging with the BTS in SLEEP mode, too. Power saving can be chosen at different levels: The NON-CYCLIC SLEEP mode (AT+CFUN=0) disables the AT interface. The CYCLIC SLEEP modes AT+CFUN=7 and 9 alternatingly activate and deactivate the AT interfaces to allow permanent access to all AT commands.
	GSM IDLE	Software is active. Once registered to the GSM network paging with BTS is carried out. The Terminal is ready to send and receive.
	GSM TALK	Connection between two subscribers is in progress. Power consumption depends on network coverage individual settings, such as DTX off/on, FR/EFR/HR, hopping sequences, antenna.
	GPRS IDLE	Terminal is ready for GPRS data transfer, but no data is currently sent or received. Power consumption depends on network settings and GPRS configuration (e.g. multislot settings).
	GPRS DATA	GPRS data transfer in progress. Power consumption depends on network settings (e.g. power control level), uplink / downlink data rates, GPRS configuration (e.g. used multislot settings) and reduction of maximum output power.
POWER DOWN	Normal shutdown after sending the AT^SMSO command, after pressing the ON/OFF key or after the activation of the ONOFF line. The RTC works continuously, but the software is not active. Interfaces are not accessible.	
Airplane mode	Airplane mode shuts down the radio part of the module, causes the Terminal to log off from the GSM/GPRS network and disables all AT commands whose execution requires a radio connection. Airplane mode can be controlled by using the AT commands AT^SCFG and AT+CALA: With AT^SCFG=MEopMode/Airplane/OnStart the Terminal can be configured to enter the Airplane mode each time when switched on or reset. The parameter AT^SCFG=MEopMode/Airplane can be used to switch back and forth between Normal mode and Airplane mode any time during operation. Setting an alarm time with AT+CALA followed by AT^SMSO wakes the module up into Airplane mode at the scheduled time.	

3.4 Terminal Circuit

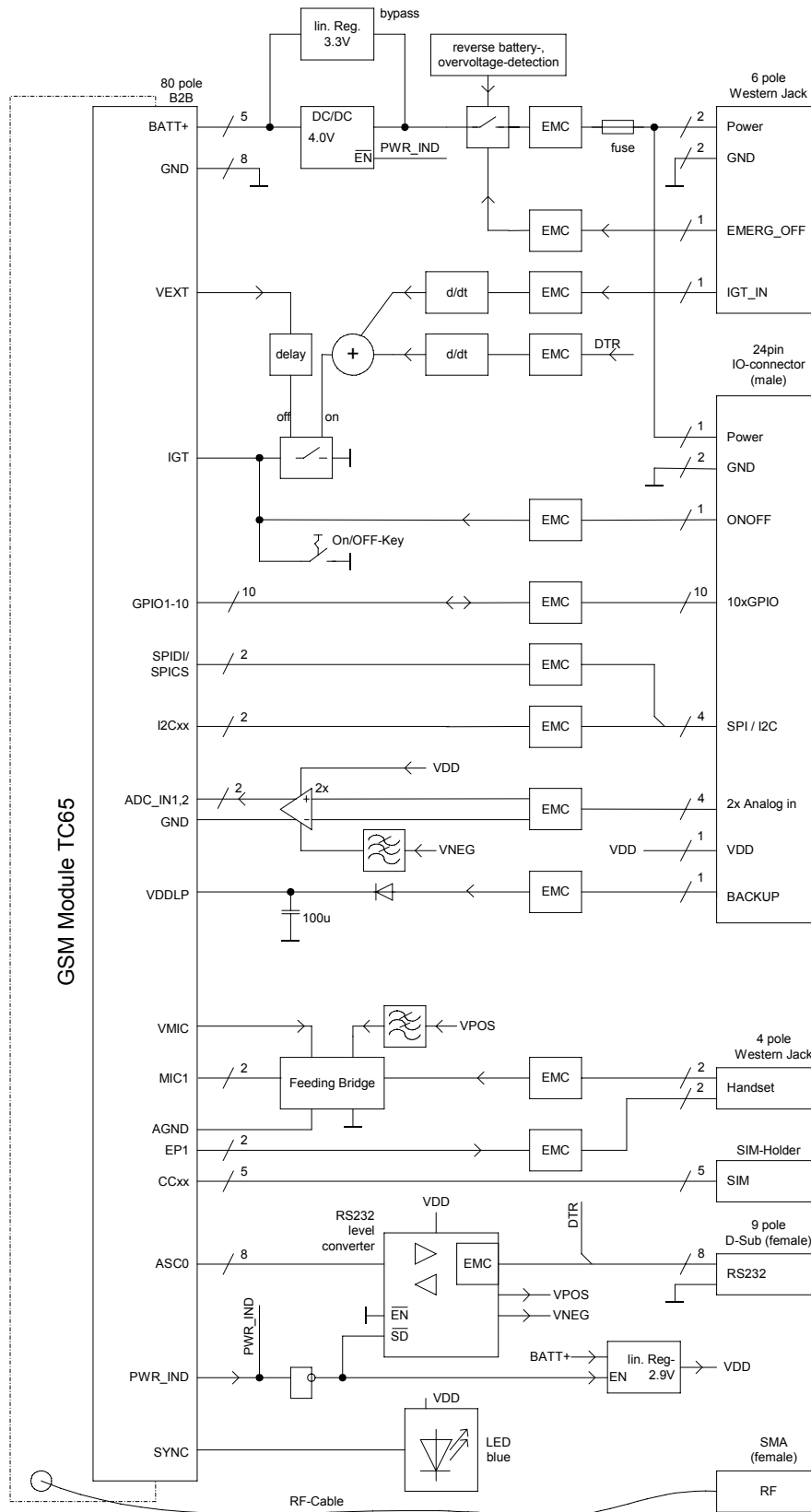

Figure 4: TC65 Terminal circuit block diagram

3.5 Power Supply

The power supply of the TC65 Terminal has to be a single voltage source of POWER=8V...30V capable of providing a peak during an active transmission. The uplink burst causes strong ripples (drop) on the power lines.

The TC65 Terminal is protected from supply voltage reversal and overvoltage. An internal fuse ensures an electrical safety according to EN60950. This fuse is not removable.

A fast acting fuse $I \geq 0.8A$ with melting integral I^2t (0.8 ... 1.5 A²s) is necessary to use the TC65 Terminal at a 24V power supply system for vehicles.

The power supply must be compliant with the EN60950 guidelines.

Table 6: Pin assignment of the Western plug for power supply

Pin	Signal name	Use
1	POWER	Power supply
2	POWER	Power supply
3	EMERGOFF	Signal for POWER DOWN mode
4	IGT_IN	Ignition input
5	GND	Ground
6	GND	Ground

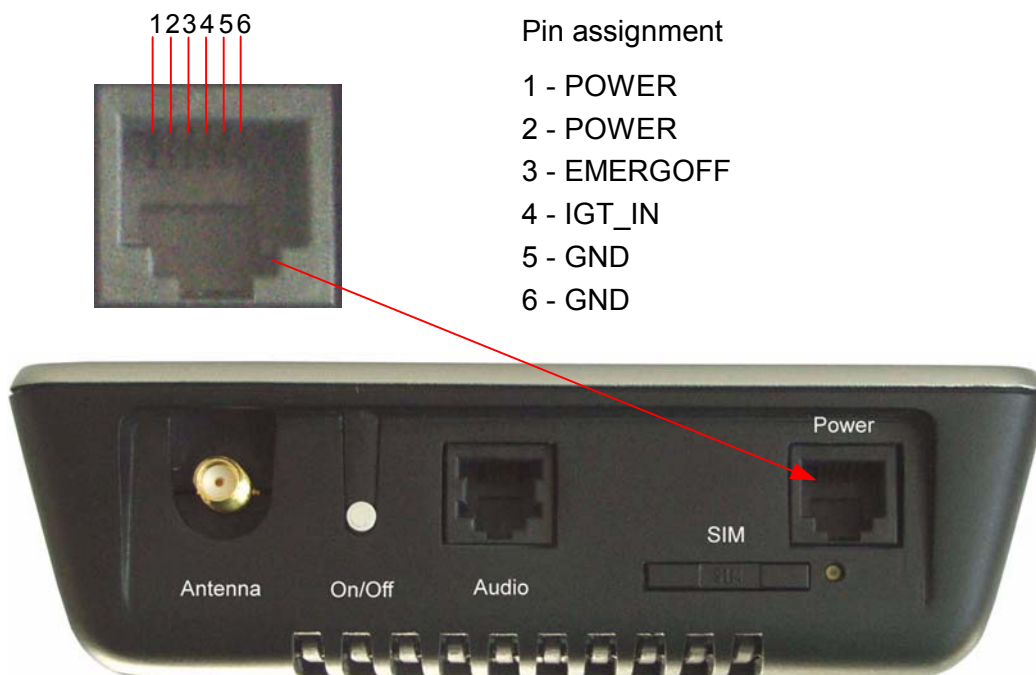

Figure 5: Female 6-pole Western plug for power supply, ignition, emergency off

3.5.1 Switch on TC65 Terminal

There are several ways to turn on the TC65 Terminal:

- *Switch on via ON/OFF push button or via ONOFF signal line on IO interface connector:* The major approach is to switch on the TC65 Terminal by pressing the ON/OFF key. The ONOFF pin of the IO connector is connected in parallel to the ON/OFF key and makes possible to control the TC65 Terminal from a remote unit.
- *Switch on via IGT_IN line (power supply connector) or DTR line (serial connector).* The rising edge of the IGT_IN line or the DTR line voltage generates an ignition signal (impulse) so that it is possible to switch on the TC65 Terminal from the host or by remote control.
- *Switch on via recommended power supply unit:* By connecting the TC65 Terminal with the recommended power supply unit the TC65 Terminal starts to work. See Chapter 7 for ordering information the power supply unit.

Switch on condition: When the TC65 Terminal is off the ON/OFF push button or the ON/OFF signal line must be asserted for at least 400 ms and then released.

3.5.2 Reset TC65 Terminal

An easy way to reset the TC65 Terminal is entering the command AT+CFUN=x,1. For details on AT+CFUN please see [1].

3.5.3 Switch off TC65 Terminal

There are several ways to turn off the TC65 Terminal:

- *Software controlled shutdown by AT^SMSO command:* The AT^SMSO command lets the TC65 Terminal log off from the network and allows the software to enter into a secure state and save data before disconnecting the power supply. The mode is referred to Power-down mode. In this mode only the RTC stays active.
- *Software controlled shutdown via ON/OFF push button or ONOFF line at IO interface connector:* The TC65 Terminal will be switched off by pressing the ON/OFF push button or by activating the ONOFF signal for >1s. The shutdown behavior is identical to the behavior when using the AT^SMSO command.
- *Shutdown via EMEROFF line (power supply connector):* The TC65 Terminal will be switched off by activating the EMERGOFF signal for >1s. All information stored in the volatile memory will get lost.
- *Automatic shutdown:* This takes effect when the board temperature is out of range or when undervoltage or overvoltage conditions occur.

3.5.4 Disconnecting Power Supply

Before disconnecting the power supply from the POWER pin make sure the TC65 Terminal is in a safe condition. A safe condition is waiting 1s after the "^SHUTDOWN" result code has been indicated.

3.5.5 Signal States after Startup

Table 7 describes the various states each interface pin passes through after startup and during operation.

The state of several pins will change again once the respective interface is activated or configured by AT command.

Table 7: Signal states

Signal name	Undefined state during startup	Defined state after initialization	Active state after configuration by AT command		
			GPIO	SPI	I ² C
RXD	O, L	O, L			
TXD	I	I			
CTS	O, H	O, H			
RTS	I	I			
DTR	I	I			
DCD	O, H	O, L			
DSR	O, H	O, L			
RING	O, L	O, L			
SPIDI	I	Tristate		I	Tristate
SPICS	I	O, H		O, L	Tristate
I2CDAT_SPIDO	I	Tristate		O, L/H	IO
I2CCLK_SPICLK	I	Tristate		O, L/H	O, OD
IO1	I, PU	Tristate	IO		
IO2	I, PU	Tristate	IO		
IO3	I, PU	Tristate	IO		
IO4	I, PD	Tristate	IO		
IO5	O, L	Tristate	IO		
IO6	I	Tristate	IO		
IO7	I	Tristate	IO		
IO8	O, L	Tristate	IO		
IO9	I	Tristate	IO		
IO10	I	Tristate	IO		

Abbreviations used in Table 7:

L = Low level
H = High level
L/H = Low or high level
I = Input

O = Output
OD = Open Drain
PD = Pull down with min +15µA and max. +100µA
PU = Pull up with min -15µA and max. -100µA

3.6 RS-232 Interface

The serial interface of the TC65 Terminal is intended for the communication between the GSM module and the host application. This RS-232 interface is a data and control interface for transmitting data, AT commands and providing multiplexed channels. EMC immunity complies with the vehicular environment requirements according to EN 301 489-7.

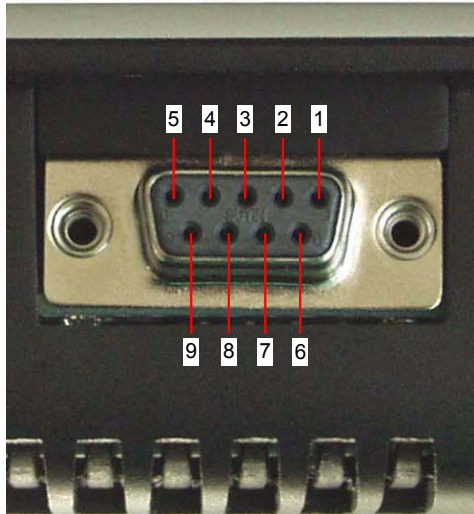
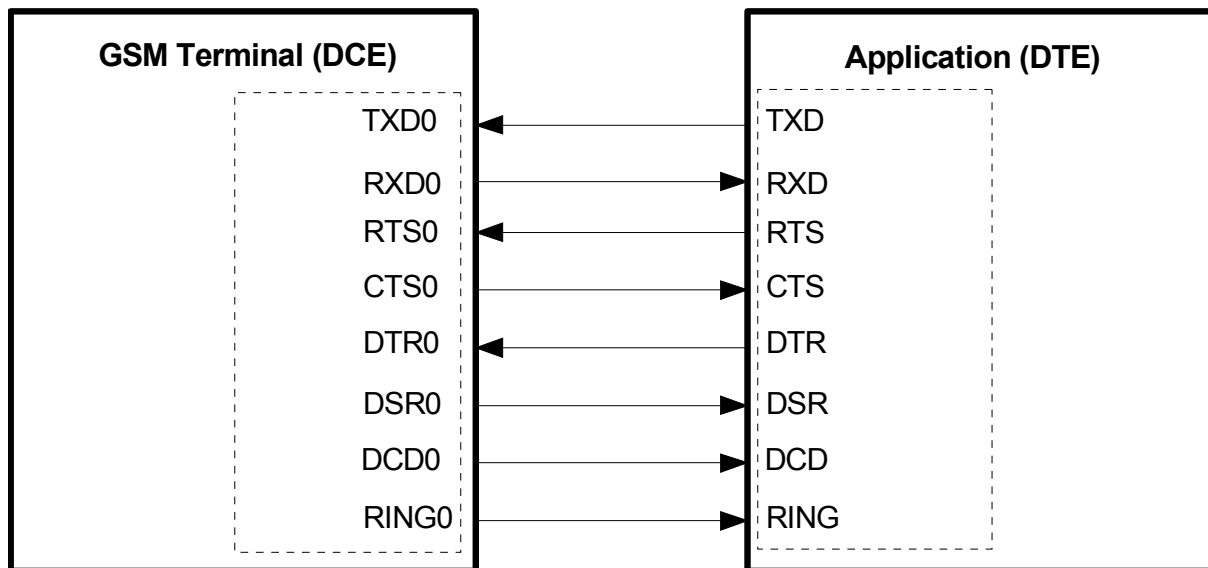

Figure 6: Pin assignment RS-232 (D-Sub 9-pole female)

Table 8: 9-pole D-Sub (female) RS-232

Pin no.	Signal name	I/O	Function of application
1	DCD	O	Data Carrier Detected
2	RXD	O	Receive Data
3	TXD	I	Transmit Data
4	DTR	I	Data Terminal Ready Attention: Low-to-high transition of the DTR line activates the ignition signal of the GSM module
5	GND	-	Ground
6	DSR	O	Data Set Ready
7	RTS	I	Request To Send
8	CTS	O	Clear To Send
9	RING	O	Ring Indication



TC65 Terminal is designed for use as a DCE. Based on the conventions for DCE-DTE connections it communicates with the customer application (DTE) using the following signals:

- Port TxD @ application sends data to TXD of TC65 Terminal
- Port RxD @ application receives data from RXD of TC65 Terminal

The RS-232 interface is implemented as a serial asynchronous transmitter and receiver conforming to ITU-T V.24 Interchange Circuits DCE. It is configured for 8 data bits, no parity and 1 stop bit and can be operated at fixed bit rates from 300bps to 460,800bps. Autobauding supports bit rates from 1,2bps to 460,800bps. Hardware handshake using the /RTS and /CTS signals and XON/XOFF software flow control are supported.

In addition the modem control signals DTR, DSR, DCD and RING are available. The modem control signal RING (Ring Indication) can be used to indicate, to the cellular device application, that a call or Unsolicited Result Code (URC) is received.

3.7 Audio Interface

The audio interface provides one analog input for a microphone and one analog output for an earpiece.

- The microphone input and the earpiece output are balanced.
- For electret microphones a supply source is implemented.
- The microphone supply characteristics are optimized for the recommended Votronic handset. For ordering Information see Chapter 7.
- This handset has been used for the reference handset for type approval. An extra approval must be obtained for integrating other handsets or amplifiers.

The amplification of sending direction, receiving direction and sidetone depends on the current audio mode.

EMC immunity complies with the vehicular environment requirements according to EN 301 489-7.

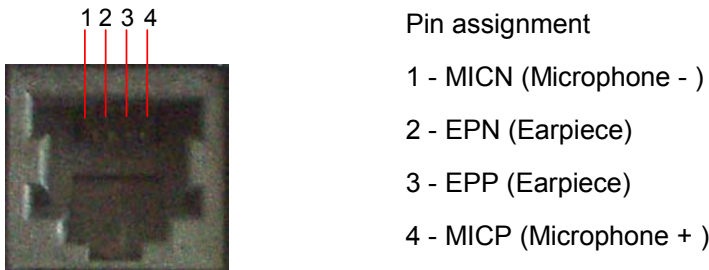
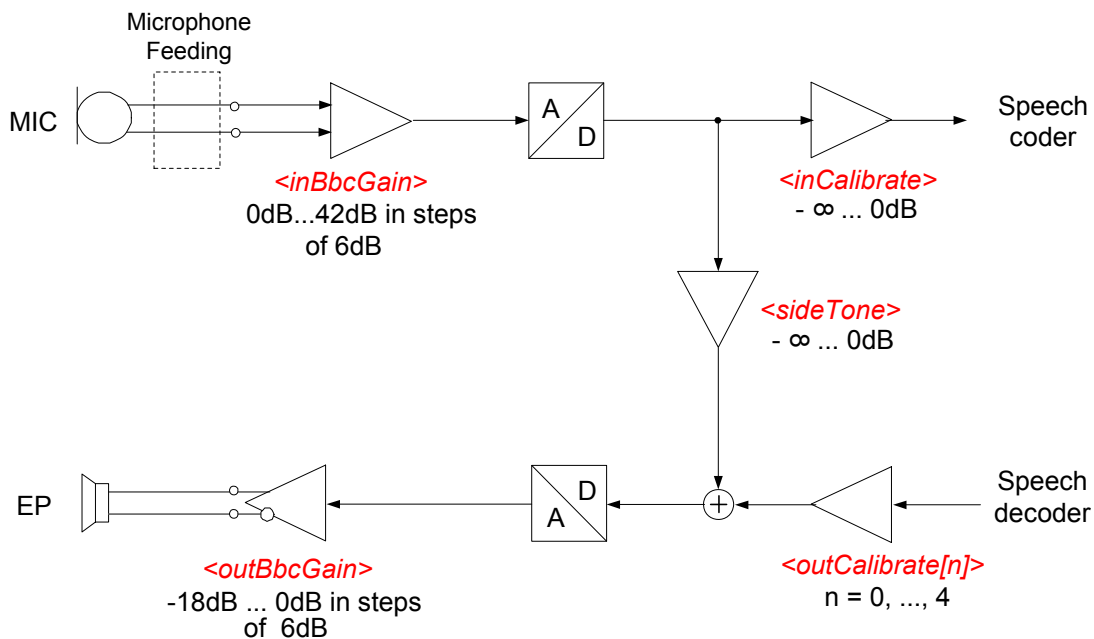

Figure 7: Audio Western plug (4-pole female)



AT parameters are given in brackets <...> and marked red and italic.

Figure 8: Audio block diagram

3.7.1 Supported Audio Modes

The audio interface can be configured by AT commands. Refer to [1] for details.

The electrical characteristics of the voiceband part vary with the audio mode. Specifications are listed in Table 9. To suit several types of audio equipment, three audio modes given by default can be selected by the AT command AT^SNFS.

Regarding audio performance, compliance with the TS 51010-1 specification and GCF recommendations has been certified for the parameters provided by audio mode 1 and audio interface 1. The settings are optimized for the reference handset (type Votronic) connected to the TC65 Terminal (see chapters 6.1 and 7). To ensure that the reference parameters are always within the limits demanded by the standards they cannot be changed by AT command. Furthermore, the reference parameters are set as factory default.

In audio mode 4 and 5, the gain in the microphone, earpiece and the sidetone path can be adjusted from the cellular device application by using further AT commands.

Please note that the 2nd audio interface of the TC65 module is not connected in the TC65 Terminal. Audio modes 2, 3 and 6 can be selected by setting AT^SAIC=2,1,1, for further details refer to [1].

Table 9: Audio modes

Mode No AT^SNFS=	1 (Default settings, not adjustable)	4	5
Name	Default Handset	User Handset	Plain Codec 1
Purpose	Recommended handset	User provided handset	Direct access to speech coder
Gains programmable via AT command	NO	YES	YES
Sidetone	YES	YES	YES
Volume control	NO	YES	YES
Echo control (send)	Cancellation and suppression	Cancellation and suppression	NO
Noise suppression	YES	YES	NO
MIC input signal for 0dBm0 @ 1024 Hz (at default gain settings)	12.5 mV	12.5 mV	400 mV
Earpiece output signal in mV eff. @ 0dBm0, 1024 Hz, no load (at default gain settings); @ 3.14 dBm0	475 mV	475 mV (default @ max volume)	1.5 V 6.0 Vpp
Sidetone gain (at default settings)	24.9 dB	24.9 dB	-∞ dB

3.7.2 Speech Processing

The speech samples from the ADC are handled by the DSP of the baseband controller to calculate e.g. amplifications, sidetone, echo cancellation or noise suppression depending on the configuration of the active audio mode. These processed samples are passed to the speech encoder. Received samples from the speech decoder are passed to the DAC after post processing (frequency response correction, adding sidetone etc.).

Full rate, half rate, enhanced full rate, adaptive multi rate (AMR), speech and channel encoding including voice activity detection (VAD) and discontinuous transmission (DTX) and digital GMSK modulation are also performed on the GSM baseband processor.

Note: With regard to acoustic shock, the cellular application must be designed to avoid sending false AT commands that might increase the amplification, e.g. for a high sensitive earpiece.

3.8 Antenna Interface

In order to send or receive data connect an external RF antenna to the SMA connector which is internally connected to the RF signal of the GSM module.

Please consider that the recommended antenna equipment has been chosen to achieve optimum RF performance when operating the TC65 Terminal. Siemens does not accept warranty claims for damage caused by inappropriate equipment connected to the antenna connector.

3.9 SIM Interface

The SIM interface is intended for 3V and 1.8V SIM cards. The card holder is a five wire interface according to GSM 11.11. A sixth pin has been added to detect whether or not the SIM card drawer is inserted.

Removing and inserting the SIM card during operation requires the software to be reinitialized. Therefore, after reinserting the SIM card it is necessary to restart TC65 Terminal.



Note: No guarantee can be given nor any liability accepted, if loss of data is encountered after removing the SIM card during operation.

Also, no guarantee can be given for properly initializing any SIM card that the user inserts after having removed a SIM card during operation. In this case the TC65 Terminal must be restarted by the application.

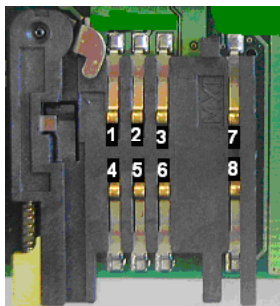

Figure 9: Pin location of the Molex SIM card holder and position

Table 10: Pin assignment – SIM card holder

Pin number on holder	Signal name	I/O	Function
1	VSIM	O	Supply voltage for SIM card is generated by the module.
2	CCRST	O	Chip card reset, prompted by the module
3	CCCLK	O	Chip card clock
4,8	GND	-	Ground
5	CCVPP	-	Not connected
6	CCIO	I/O	Serial data line, bi-directional
7	CCIN	I	Chip card drawer detection 0 = Chip card drawer inserted 1 = Chip card drawer not inserted Input on the baseband processor for detecting the chip card drawer in the holder; if the SIM is removed during operation the interface is shut down immediately to prevent destruction of the SIM.

3.10 IO Interface

Via the IO interface connector the following interfaces and functions are provided.

- Programmable GPIOs
- I²C bus
- SPI interface
- Two analog inputs (balanced)
- Power supply
- Backup supply
- VDD supply
- On/Off switch of the TC65 Terminal
- Pulse counter

The total cable length of the digital lines for I²C and SPI interfaces should not exceed 150mm.

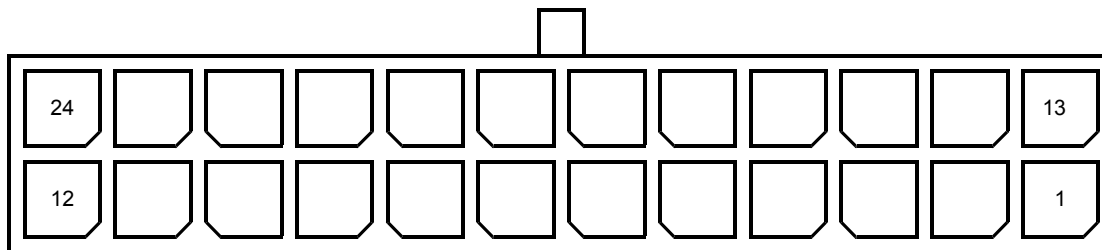

Figure 10: IO interface connector front view

Table 11: Assignment of the IO interface connector

Pin	Signal name	I/O	Description
1	I2CCLK_SPICLK	O	I2C or SPI Clock
2	I2CDAT_SPIDO	I/O	I2C Data or SPI Data out
3	GPIO3	I/O	Programmable GPIO
4	GPIO4	I/O	Programmable GPIO
5	GPIO5	I/O	Programmable GPIO
6	GPIO6	I/O	Programmable GPIO
7	GPIO2	I/O	Programmable GPIO
8	GPIO1	I/O	Programmable GPIO
9	ADC2_IN_P	I	Balanced analog 2 positive input
10	ADC2_IN_N	I	Balanced analog 2 negative input
11	BACKUP	I	Backup battery
12	GND		Ground for power supply
13	SPICS	O	SPI Select
14	SPIDI	I	SPI Data In
15	GPIO9	I/O	Programmable GPIO
16	GPIO10	I/O	Programmable GPIO/ Pulse counter
17	GPIO7	I/O	Programmable GPIO
18	GPIO8	I/O	Programmable GPIO
19	VDD	O	Signal supply voltage
20	ONOFF	I	Ignition
21	ADC1_IN_P	I	Balanced analog 1 positive input
22	ADC1_IN_N	I	Balanced analog 1 negative input
23	GND		Signal ground
24	POWER	I	Power supply

3.10.1 GPIOs

The TC65 Terminal provides 10 GPIO pins at the IO interface connector. Each GPIO line is ESD protected and a serial resistor of 100 Ohm is added. This avoids short circuits and is especially important in the first stages of development where the Java application is not yet fully implemented. The signal direction (input/output) of the GPIO lines is selectable with AT commands. Figure 11 shows the position of the GPIO pins at the IO interface connector.

Alternatively GPIO pin10 can be used to configure, to start or stop a pulse counter for an input range of 0 to 1000 pulses per second. If the pulse counter is active the pin10 is not available for GPIO signals.

The GPIOs and the pulse counter can be configured via the following AT commands: AT^SPIO, AT^SCPIN, AT^SCPOL, AT^SCPORT, AT^SDPORT, AT^SGIO, AT^SSIO, AT^SCCNT, AT^SSCNT. For details please refer to [1].

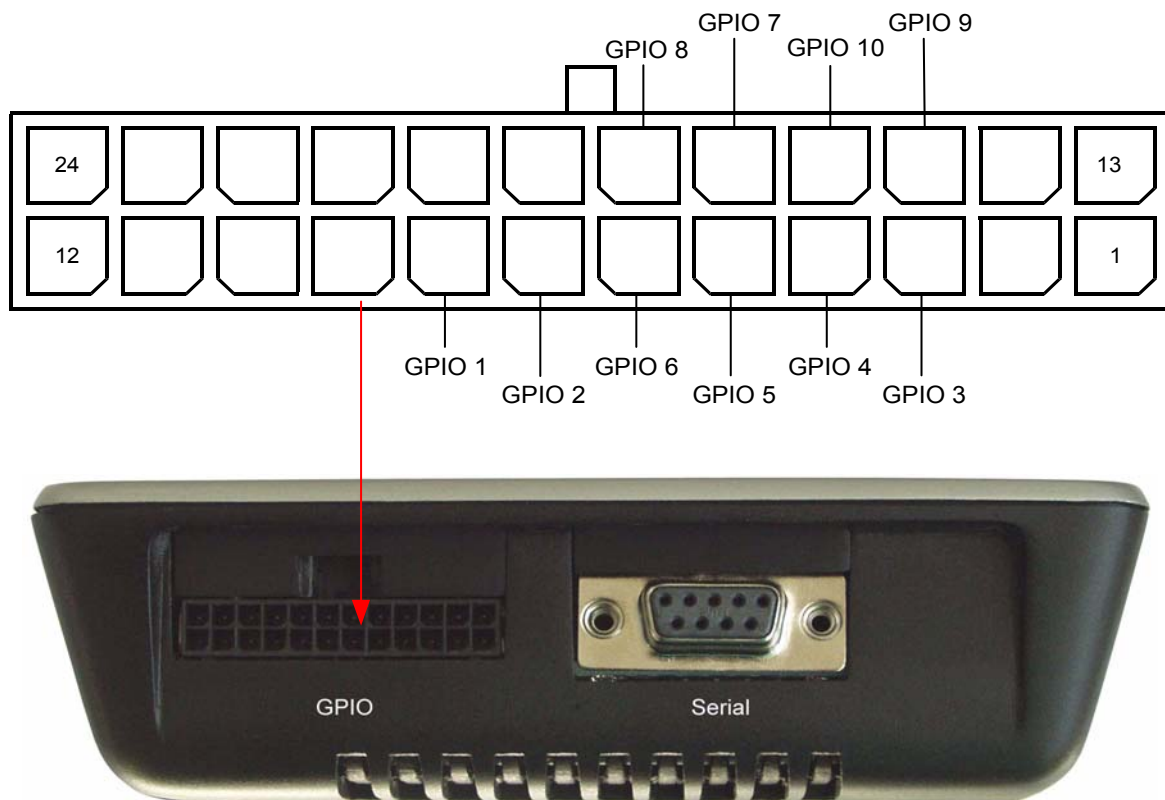

Figure 11: Location of GPIO pins

When the TC65 Terminal starts up, all GPIO pins are set to high-impedance state after initializing, as described in Chapter 3.5.5. Therefore, it is recommended to connect pull-up or pull-down resistors to all GPIO pins you want to use as output. This is necessary to keep these pins from floating or driving any external devices before all settings are done by AT command (at least AT^SPIO, AT^SCPIN), and after closing the GPIOs again.

3.10.2 Using GPIO Pin10 as Pulse Counter

The GPIO10 pin can be assigned two different functions selectable by AT command:

- The AT[^]SCPIN command configures the pin for use as GPIO.
- With AT[^]SCCNT and AT[^]SSCNT the pin can be configured and operated as pulse counter.

Both functions exclude each other. The pulse counter disables the GPIO functionality, and vice versa, the GPIO functionality disables the pulse counter.

Detailed AT command descriptions can be found in [1].

The pulse counter is designed to measure signals from 0 to 1000 pulses per second. It can be operated either in Limit counter mode or Start-Stop mode. Depending on the selected mode the counted value is either the number of pulses or the time (in milliseconds) taken to generate a number of pulses specified with AT[^]SCCNT.

The Limit counter mode, the displayed measurement result (URC “[^]SSCNT: <count>”) implies an inaccuracy <5ms. In Start-Stop mode, you can achieve 100% accuracy if you take care that no pulses are transmitted before starting the pulse counter (AT[^]SSCNT=0 or 1) and after closing the pulse counter (AT[^]SSCNT=3).

3.10.3 I²C Interface

The I²C interface is located at the IO interface connector of the TC65 Terminal.

I²C is a serial, 8-bit oriented data transfer bus for bit rates up to 400kbps in fast mode. It consists of two lines. These are the serial data line I2CDAT and the serial clock line I2CCLK. The TC65 Terminal acts as a single master device, e.g. the clock I2CCLK is driven by the Terminal. The connection I2CDAT is a bi-directional line.

Each device which is connected to the bus is software addressable by a unique address and simple master/slave relationships exists at all times. The Terminal operates as master-transmitter or as master-receiver. The customer application transmits or receives data only on request of the Terminal. To configure and activate the I²C interface use the AT[^]SSPI command described in [1].

The I²C interface is only available if the pins 1 and 2 of the IO interface connector are not used as SPI interface.

Table 12: I²C interface – signal description

Signal name	Pin	Description
I2CDAT_SPIDO	1	Data in/out – bidirectional serial data line
I2CCLK_SPICLK	2	Serial clock line

3.10.4 SPI Interface

The SPI interface is located on the IO interface connector of the TC65 Terminal. The SPI (Serial Peripheral Interface) is a synchronous serial interface for controlling and data transfer between the TC65 Terminal and a connected application. Only one application can be connected to the Terminal's SPI.

The SPI consists of four lines. These are the two data lines SPIDI/SPIDO, the clock line SPICLK and the chip select line SPICS.

The TC65 Terminal acts as a single master device, e.g. the clock SPICLK is driven by the TC65 Terminal. Whenever the SPICS pin is in a low state, the SPI bus is activated and data can be transferred from the Terminal and vice versa. The SPI interface uses two independent lines for data input (SPIDI) and data output (SPIDO). The interface supports transmission rates up to 6.5Mbit/s. Transfer rates >1.083Mbps and a length of the cable >150mm are not recommended.

The SPI interface is only available if the pins 1 and 2 of the IO interface connector are not used as I²C interface.

Table 13: SPI interface – signal description

Signal name	Pin	Description
SPICS	13	Chip select – selects and activates the external device via a low signal.
SPIDI	14	Data in – serial data input line (from the external device to the TC65 Terminal)
I2CDAT_SPIDO	1	Data out – serial data output line (from the TC65 Terminal to the external device)
I2CCLK_SPICLK	2	Serial clock line

The SPI Interface can be used in 4 different modes. Figure 12 shows the characteristics of these modes.

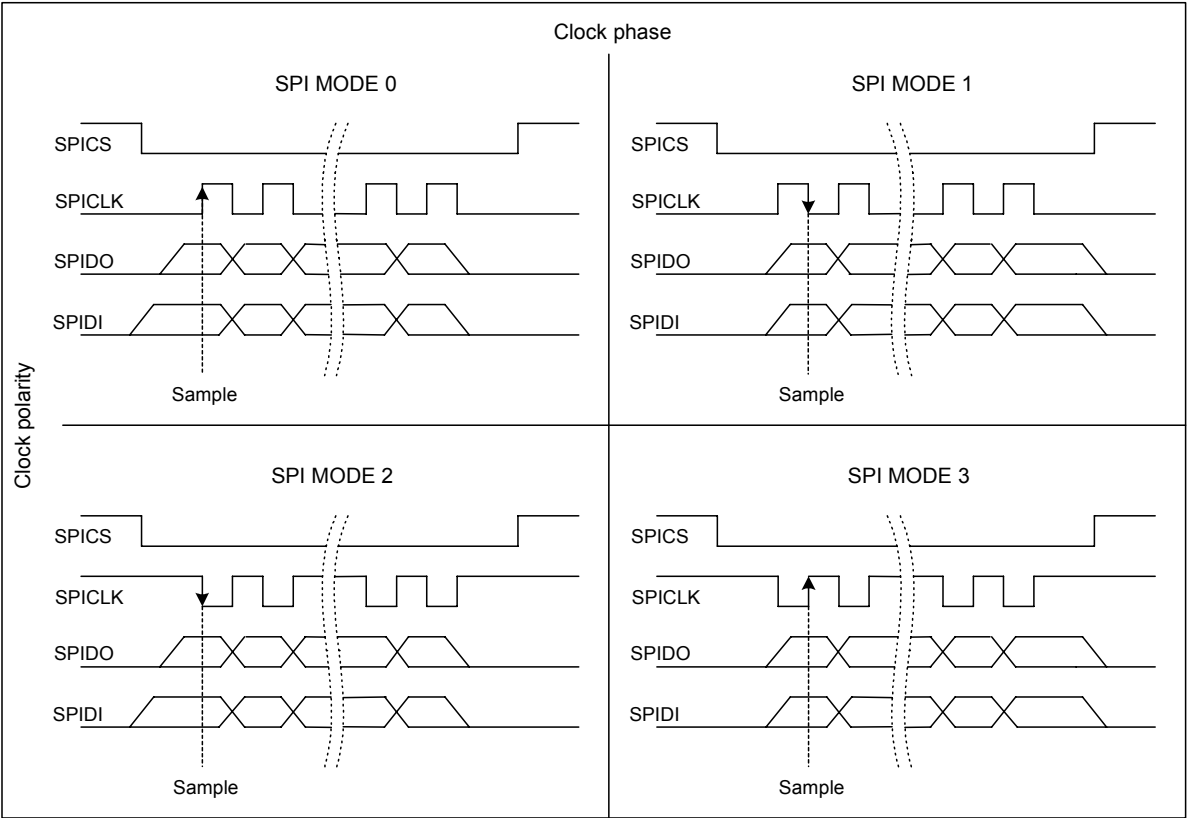

Figure 12: Characteristics of SPI modes

3.10.5 Analog-to Digital Converter (ADC)

The two balanced analog inputs are used for measuring external DC voltages in a range of 0V to 5.0V.

Note: Only positive differential voltage can be handled because of the input requirement of ADC.

Table 14: ADC signal description

Signal name	Pin	Description
ADC1_IN_N	22	Negative voltage
ADC1_IN_P	21	Positive voltage (must be more positive than ADC1_IN_N)
ADC2_IN_N	10	Negative voltage
ADC2_IN_P	9	Positive voltage (must be more positive than ADC2_IN_N)

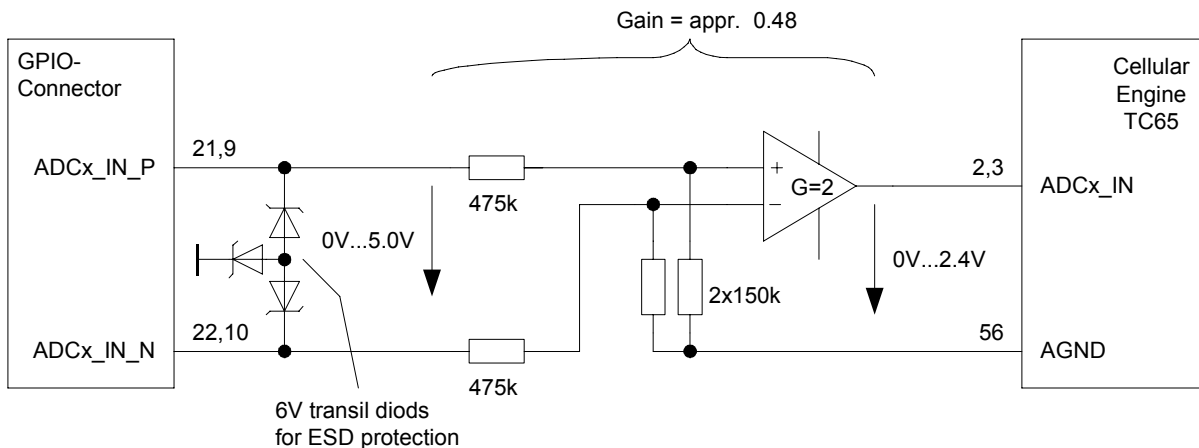

Figure 13: ADC balanced amplifier

Use the command `AT^SRADC` described in [1] to configure the analog inputs and to get the measurement results.

Note: It is necessary to recalculate measurement results because an amplifier is used to scale down the `ADCx_IN` input voltage of the TC65 Terminal (5V) to the `ADCx_IN` input voltage of the in-built TC65 module (2.4V).

Two parameters (determined and stored by factory) have to be used for offset compensation and for consideration of gain and tolerances:

Use the command `AT^SAADC` described in [1] to read out the required parameters:

<ofsx>: Offset
<amp;x> : Amplification factor (Gain*4096) x=1 for Input 1 or 2 for input 2

To recalculate the exact voltages [mV] measured at the `ADCx_IN` input use the following equation:

$$\text{Value[mV]} = (\text{<value> from AT^SRADC} - \text{<ofsx>}) * \text{<amp;x>} / 4096$$

3.10.6 RTC Backup Supply

The Real Time Clock (RTC) is supplied from a separate voltage inside the TC65T Terminal which is also active when the GSM module is in POWER-DOWN mode. An alarm function is provided for activating/deactivating GSM module (activating only to alarm mode).

You can use the BACKUP pin on the 24pole I/O connector to backup the RTC from an external battery (non-chargeable).

Table 15: RTC signal description

Signal name	Pin	Description
BACKUP	11	External battery
GND	12	Ground

If no backup battery is connected then a 100uF capacitor supplies the RTC about 6s during power interruptions.

3.10.7 Power Supply

The two pins of the power supply at the IO interface connector are directly connected to two pins of the Western Jack for power supply. This allows supplying the TC65 Terminal by using the Power connector or via the IO interface connector.

3.10.8 VDD Supply

The VDD pin at the IO interface connector may be used for supplying external circuit devices or applications and indicates the following states of the TC65 Terminal:

- VDD output voltage = 2.9V @ max. 50mA indicates Normal Operation mode or Airplane mode
- VDD output voltage = 0V indicates Power Down mode

3.10.9 ON/OFF Switch

If the ONOFF pin at the IO interface connector is active low. It can be used to switch on or switch off the TC65 Terminal.

For more information on how to to switch on or switch off the Terminal please refer to the chapters 3.5.1 and 3.5.3.

3.11 Status LED

A blue LED displays the operating status of the TC65 Terminal.

The LED can be operated in two different display modes: `AT^SSYNC=1` or `AT^SSYNC=2` (factory default). For more information of the different operating states and changing this mode please refer to [1].

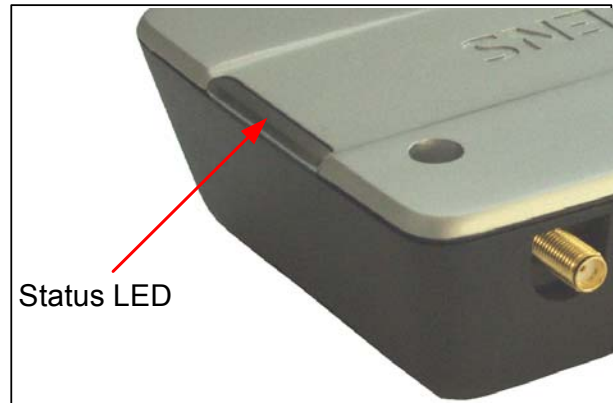

4 Mechanical Characteristics

Table 16: Mechanical characteristics

Weight	190g
Dimensions (max) L x W x H	130mm x 90mm x 38mm
Temperature range	-30°C to +65°C ambient temperature
Protection class	IP40 (Avoid exposing TC65 Terminal to liquid or moisture, for example do not use it in a shower or bath.)
Mechanical vibrations Amplitude	7.5mm at 5-200Hz sinus
Max. pulse acceleration	30g pulse with 18 ms duration time
Air humidity	5...80% (non condensing)
Class of flammability	UL94 HB
Casing material	PC/ABS Cyclopedia 1200 HF

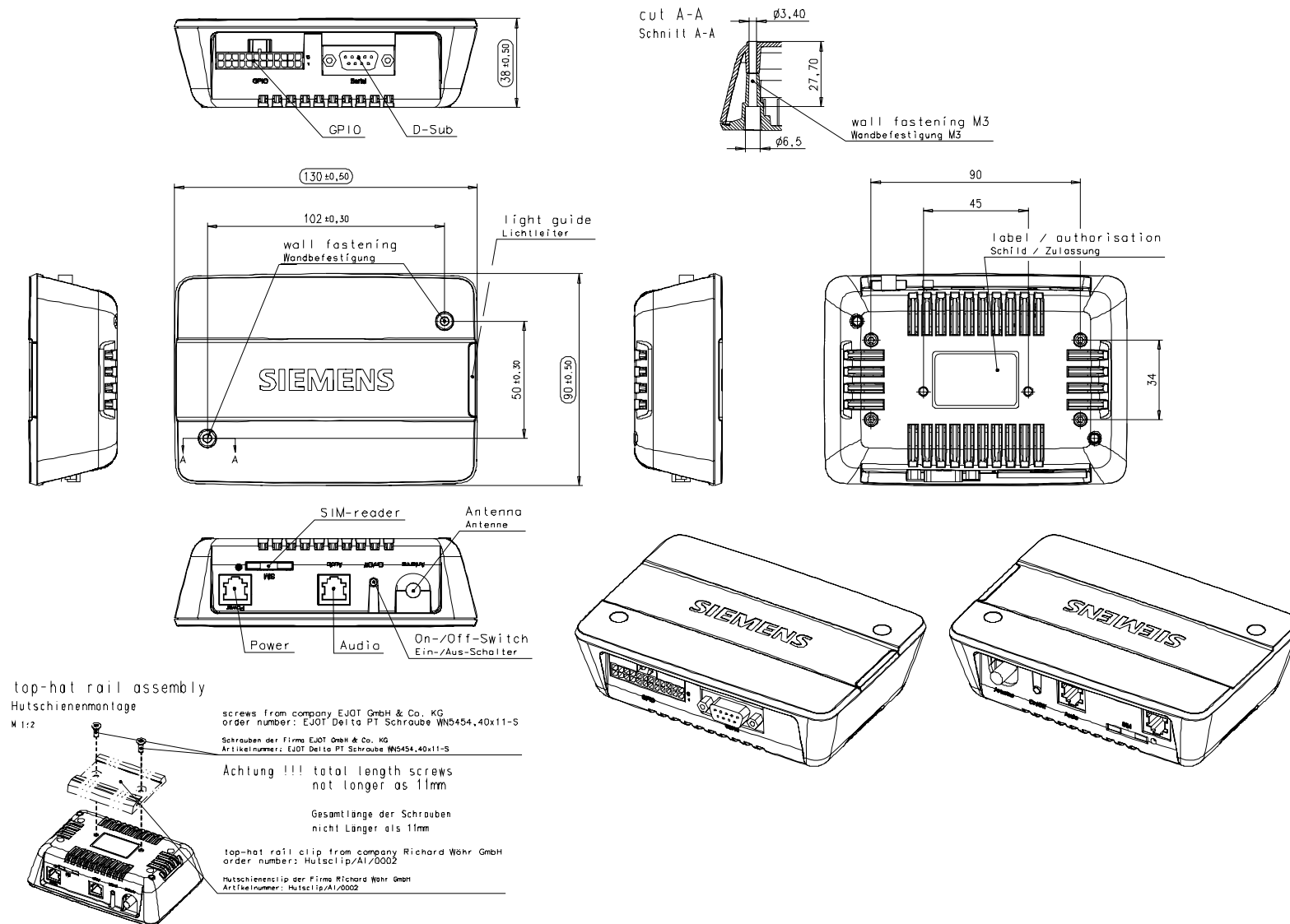

Figure 14: Mechanical dimensions

4.1 IO Interface Connector

This chapter provides specifications for the 24-pin IO interface connector which serves the I2C, SPI and GPIO interfaces of the Terminal. The type of the receptacle assembled on the TC65 Terminal is Micro Mate-N-LOK 3mm from Tyco Electronics. Mating headers can be chosen from the Tyco Micro Mate-N-LOK Series. For latest product information please contact your Micro Electronics dealer or visit the Tyco home page, for example <http://www.tycoelectronics.com>.

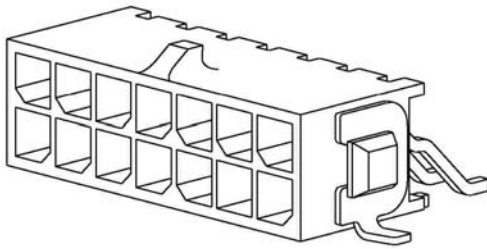

Figure 15: Tyco Micro Mate-N-LOK series on the TC65 Terminal

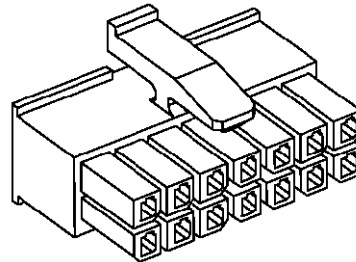

Figure 16: Mating connector Tyco Micro Mate-N-LOK series

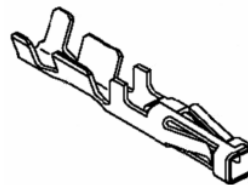

Figure 17: Receptacle contact for Tyco Micro Mate-N-LOK series

Table 17: Electrical and mechanical characteristics of the Micro Mate-N-LOK connector

Parameter	Specification
Number of contacts	24
Voltage rating	250V
Current rating	5A max.
Resistance	0.02 Ohm max. per contact
Dielectric withstanding voltage	1500VAC
Operating temperature	-40°C...+105°C
Contact centerline	3.0mm
Mating force	6.67N max. per contact
Contacts packaging method	Contacts available in strip form or loose piece (24 pieces/housing for full assembly)
Receptacle housing material	Flame-retardant black thermoplastic
Contact material	Phosphor bronze

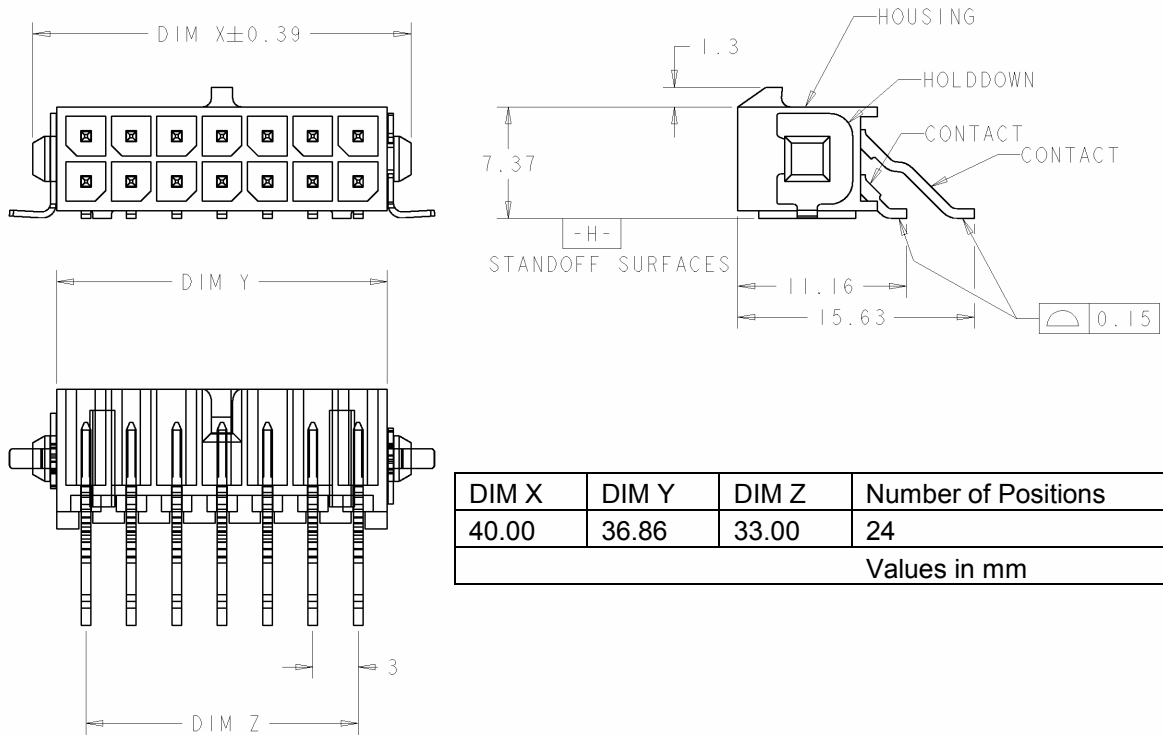

Figure 18: Mechanical dimensions of the Tyco Mate_N_LOK connector on the TC65 Terminal.

4.1.1 Recommended Mating Connector

Table 18: Ordering information for mating connector Tyco Micro Mate-N-LOK

Item	Number of positions	Ordering number
Micro Mate-N-LOK 3mm	24	2-794617-4
Crimp Snap-IN Receptacle Contacts		794606-* 794607-*

5 Electrical and Environmental Characteristics

Table 19: Absolute maximum ratings

Parameter	Port / Description	Min.	Max.	Unit
Supply voltage	POWER	-33	+33	V
Input voltage for Ignition	IGT_IN	-30	+30	V
Input voltage for emergency off	EMERGOFF	-25	+30	V
RS-232 input voltage range	TXD0, DTR0, RTS0	-30	+30	V
	RXD0, CTS0, DSR0, DCD0, RING0 (No DC Input)	-0.3	+0.3 ¹	V
Digital GPIO, SPI, I2C	GPIO1 – GPIO10, I2CCLK_SPICLK, I2CDAT_SPIDO, SPICS, SPIDI, I2CDAT_SPIDO	-0.3	+3.05 ² +0.3 ¹	V
Analog Input	ADC1_IN_P, ADC1_IN_N, ADC2_IN_P, ADC2_IN_N	-6	+6	V
Backup battery	BACKUP	-4.7	+4.7	V
On/Off- line	ONOFF (No DC Input)	-0.3	+0.3 ³	V
VDD supply voltage	VDD (No DC Input)	-0.3	+0.3 ¹	V
Microphone input line AC voltage (pins to GND)	MICP1, MICN1 (No DC Input)		0.6 ¹ 3.1 ^{2,4}	Vpp
Earpiece voltage (idle, no power)	EPP1, EPN1 (No DC Input)	-0.3	+0.3 ¹	V
Antenna Connector	No DC input	0	0	V
Immunity against air discharge of static electricity	All connectors (lines)	-8	+8	kV
Immunity against contact discharge of static electricity	All connectors (lines)	-4	+4	kV
Protection Class	IP40 (avoid exposing to liquid or moisture, for example do not use it in a shower or bath)		IP 40	
Mechanical vibrations amplitude	@ 5-200Hz		7.5	mm
Mechanical pulse-acceleration	@ 18ms duration		30	G

¹ For Power Down and Power Off.

² For all operation modes.

³ Only Power Off.

⁴ A call is established or the AT command "AT^SNFM=,1" was executed.

Table 20: Operating conditions

Parameter	Min	Typ	Max	Unit
Ambient temperature	-30	25	65 ^{*)}	°C
Supply voltage V _{POWER} measured at (6-pole) western jack plug (1, 2 to 5,6)	7.6 lowest voltage (minimum peak) incl. all ripple and drops	12	30	V

^{*)} Continuous operation at 65°C environmental temperature is not possible in every operating mode due to intrinsic heating of the TC65 Terminal.

The level of intrinsic heating depends on several factors depending on the level of the supply voltage, the operating mode (GPRS/GSM) and the network coverage. The maximum possible environmental temperature in GPRS Class 12 operating mode (MS-configuration 1down/4up, PCL5/Gamma3, 12V supply voltage, 900MHz band, with power reduction) is about 45°C. When this temperature is exceeded the TC65 Terminal will send a request to the base station for changing the GPRS-Class (e.g. from GPRS Class 12 to GPRS Class 8). At a successful change of the GPRS class the intrinsic heating of the TC65 Terminal will be reduced. If the board temperature decreases by an amount of 15°C the GPRS Class will be stepped up again.

Continuous operation in Talk mode is possible up to an environmental temperature of about 67°C (12V, 900MHz, PCL5). With decreasing transmit power of the TC65 Terminal, the maximum possible environmental temperature increases at which a GPRS continuous operation at PCL5/Gamma3 is possible.

For a short time it is also possible to establish a GPRS Class 12 connection at PCL5/Gamma3 and at an ambient temperature of 65°C. Starting a data download in GPRS Class 12 mode with power reduction at 65°C environmental temperature the request for a change of the GPRS Class will be enabled after 7 minutes. This information applies to 12V supply voltage. At 8V resp. 30V the intrinsic heating is higher, whereby the maximum possible environmental temperature will be lower.

The following table shows the highest possible ambient temperatures at which the temperature of the NTC will reach a final value of 81°C (GPRS Class 10,12 Temperature of GPRS Class Change) or the final shut down temperature 90°C (GPRS Class 8 and Voice Call).

Table 21: Highest temperatures

Terminal horizontal, normal position	Highest possible ambient temperature
GPRS Class 8 PCL5/Gamma3	67°C
GPRS Class 10 PCL5/Gamma3	48°C
GPRS Class 12 PCL5/Gamma3 with Power Reduction	45°C
GPRS Class 12 PCL5/Gamma3 without Power Reduction	34°C

The following table shows the longest possible duration of a connection until 81°C (Temperature of GPRS Class Change) are reached at the NTC when the ambient temperature is 65°C.

Table 22: Longest duration until 81°C are reached

Terminal horizontal, normal position	Longest possible duration of connection
GPRS Class 10 PCL5/Gamma3	11 minutes
GPRS Class 12 PCL5/Gamma3 with Power Reduction	7 minutes
GPRS Class 12 PCL5/Gamma3 without Power Reduction	---

The following table shows the longest possible duration of connection when the GPRS Class Change from GPRS Class 12 or 10 to GPRS Class 8 did not work properly and 90°C (Temperature of Hardware shut off) will be reached at the NTC (ambient temperature is 65°C).

Table 23: Longest duration when GPRS Class Change does not work properly

Terminal horizontal, normal position	Longest possible duration of connection
GPRS Class 8 PCL5/Gamma3	Continuous operation
GPRS Class 10 PCL5/Gamma3	22 minutes
GPRS Class 12 PCL5/Gamma3 with Power Reduction	14 minutes
GPRS Class 12 PCL5/Gamma3 without Power Reduction	---

5.1 Characteristics of the Power Supply

Table 24: Characteristics of the power supply

Parameter	Description	Conditions	Min	Typ	Max	Unit		
V _{POWER}	Operating Voltage	for one minute	8 ⁵	12	30	V		
					33	V		
I _{POWER}	Average supply current (average time 3 min.) @25°C @ worst case: GSM 900 max power level	Power Down mode	@8V	0.45		mA		
			@12V	0.50				
			@30V	0.80				
		SLEEP mode	@8V	40		mA		
			@12V	29				
			@30V	18				
		IDLE mode	@8V	50		mA		
			@12V	36				
			@30V	21				
		TALK mode	@8V	277		mA		
			@12V	184				
			@30V	82				
		Data GPRS 1Tx / 4Rx	@8V	260		mA		
			@12V	173				
			@30V	77				
		Data GPRS 2Tx / 3Rx (Power reduction = 3dB)	@8V	378		mA		
			@12V	248				
			@30V	108				
		Data GPRS 4Tx / 1Rx (Power reduction = 6dB)	@8V	500		mA		
			@12V	330				
			@30V	140				
		I _{POWER_P} ⁶	Peak supply current during transmission slot (577µs * No. of Tx every 4.6ms)	Power control level for Pout max	@8V	1500		mA
					@12V	910		
					@30V	340		
t _{PLUS-Fail}	Allowed power fail time without terminal reset or power down	After this time the Terminal will be reset or switched off			1	ms		
	Allowed power fail time without RTC reset	Backup Battery not connected, After this time the RTC will be reset		6		s		

⁵ Lowest voltage (minimum peak) incl. all ripple and drops >7.6V including voltage drop, ripple and spikes, measured at western jack (6-pole) pin (1 to 6)

⁶ Typical values measured with antenna impedance = 50Ohm (return loss >20dB)
Maximum values measured with mismatched antenna

5.2 Characteristics of On/Off control

Table 25: Characteristics On/Off control

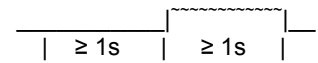
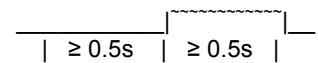
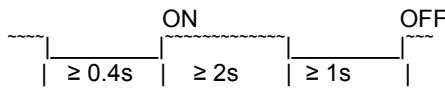
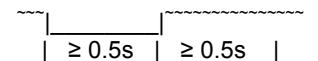
Function	Signal name	IO	Signal form and level	Comment
Emergency OFF	EMERGOFF	I	$R_i \approx 100\text{k}\Omega$ $V_{L\text{max}} = 0.8\text{V}$ $V_{L\text{min}} = -0.3\text{V}$ $V_{H\text{min}} = 4.5\text{V}$ $V_{H\text{max}} = 30\text{V}$ signal  Rise time $\leq 100\text{ms}$	Emergency-off switches the power supply of the Terminal off. Data stored in the volatile memory will be lost, if used the emergency off. If unused keep pin open.
Ignition	IGT_IN	I	$R_i \approx 100\text{k}\Omega$, $C_i \approx 100\text{nF}$ $V_{L\text{max}} = 0.8\text{V}$ $V_{L\text{min}} = -0.3\text{V}$ $V_{H\text{min}} = 8\text{V}$ $V_{H\text{max}} = 30\text{V}$ signal  Rise time $\leq 100\text{ms}$	This signal switches the mobile ON. It's possible to connect IGT_IN directly with POWER. If unused keep pin open.
	ONOFF	I	$R_i \approx 30\text{k}\Omega$, $C_i \approx 10\text{nF}$ $V_{iL\text{max}} = 0.5\text{V}$ at $I_{\text{max}} = -150\mu\text{A}$ $V_{oH\text{max}} = 4.2\text{V}$  Rise time $\leq 1\text{ms}$	This signal switches the mobile ON and OFF. This line must be driven low by an open drain or open collector driver. If unused keep pin open.
RS232	DTR	I	$V_{i\text{min}} = \pm 3\text{V}$ signal  Rise time $\leq 1\text{ms}$	This signal switches the module ON with the low high transition.

5.3 Characteristics of the RS-232 interface

Table 26: Characteristics of the RS-232 interface

Function	Signal name	IO	Signal from and level	Comment
RS232	TXD	I	$R_{i\min} = 3k\Omega$	If lines are unused keep pin open. It could be possible to start the module with DTR.
	RTS	I	$V_{iL\max} = 0.6V$	
	DTR	I	$V_{iH\min} = 2.4V$ $V_{i\max} = \pm 25V$	
	RXD	O	$V_{o\min} = \pm 5V$ at 3k Ω load	
	CTS	O	Leakage Current max = $\pm 25\mu A$ at Module power down.	
	DSR	O		
	DCD	O		
RING	O			

5.4 Characteristics of the SIM Interface for Use with 3V Cards

Table 27: Characteristics of the SIM interface for use with 3V cards

Function	Signal name	IO	Signal form and level	Comment
Reset	CCRST	O	$R_o \approx 47\Omega$ $V_{oL\max} = 0.25V$ at $I = +1mA$ $V_{oH\min} = 2.5V$ at $I = -0.5mA$ $V_{oH\max} = 2.95V$	All signals of SIM interface are protected against ESD with a special diode array.
Data IO	CCIO	I/O	$R_i \approx 4.7k\Omega$ $V_{iL\max} = 0.75V$ $V_{iL\min} = -0.3V$ $V_{iH\min} = 2.1V$ $V_{iH\max} = CCVCC_{\min} + 0.3V = 3.05V$ $R_o \approx 100\Omega$ $V_{oL\max} = 0.3V$ at $I = +1mA$ $V_{oH\min} = 2.5V$ at $I = -0.5mA$ $V_{oH\max} = 2.95V$	
Clock	CCCLK	O	$R_o \approx 100\Omega$ $V_{oL\max} = 0.3V$ at $I = +1mA$ $V_{oH\min} = 2.5V$ at $I = -0.5mA$ $V_{oH\max} = 2.95V$	
Supply	CCVCC	O	$V_{o\min} = 2.75V$ $V_{o\text{typ}} = 2.85V$ $V_{o\max} = 2.95V$ $I_{o\max} = -20mA$	
Ground	CCGND		Ground	

5.5 Characteristics of the SIM interface for Use with 1.8V Cards

Table 28: Characteristics of the SIM interface for use with 1.8V cards

Function	Signal name	IO	Signal form and level	Comment
Reset	CCRST	O	$R_O \approx 47\Omega$ $V_{OLmax} = 0.25V$ at $I = +1mA$ $V_{OHmin} = 1.45V$ at $I = -0.5mA$ $V_{OHmax} = 1.90V$	All signals of SIM interface are protected against ESD with a special diode array.
Data IO	CCIO	I/O	$R_I \approx 4.7k\Omega$ $V_{ILmax} = 0.45V$ $V_{IHmin} = 1.35V$ $V_{IHmax} = CCVCCmin + 0.3V = 2.00V$ $R_O \approx 100\Omega$ $V_{OLmax} = 0.3V$ at $I = +1mA$ $V_{OHmin} = 1.45V$ at $I = -0.5mA$ $V_{OHmax} = 1.90V$	
Clock	CCCLK	O	$R_O \approx 100\Omega$ $V_{OLmax} = 0.3V$ at $I = +1mA$ $V_{OHmin} = 1.45V$ at $I = -0.5mA$ $V_{OHmax} = 1.90V$	
Supply	CCVCC	O	$V_{Omin} = 1.70V$ $V_{Otyp} = 1.80V$ $V_{Omax} = 1.90V$ $I_{Omax} = -20mA$	
Ground	CCGND		Ground	

5.6 Characteristics of the Audio Interface

Table 29: Characteristics of the audio interface

Function	Signal name	IO	Parameter	Min.	Typ.	Max.	Unit
Microphone	MICP, MICN	I	DC (no load) at MICP	5.3	5.4	5.6	V
			DC at MICP in POWER DOWN		0V		V
			DC (no load) at MICN		0		V
			DC Resistance differential MICN, MICP (balanced)	4.6	4.7	4.8	kOhm
			Impedance Zi (balanced)	3.9	4.0	4.1	kOhm
			Input level Uimax			0.6	V _{PP}
			Restricted Input level Uires ⁷			1.6	V _{PP}
			Gain range 6 dB steps	0		42	dB
			Frequency Range	200		3900	Hz
			fine scaling by DSP (inCalibrate)	-∞		0	dB
Earpiece	EPP, EPN	O	Impedance (balanced)	8			Ohm
			AC output level UO Gain = 0dB @ 3.14 dBm0 no load		5.97		V _{PP}
			Gain range	-18		0	dB
			Gain accuracy			0.8	dB
			Frequency area	200		3900	Hz
			DC Offset (balanced)			100	mV
			Attenuation distortion for 200...3900Hz			1	dB
Out-of-band discrimination		70		dB			
LEAudio			Length of Audio (Handset) cable			3	m

Unless otherwise stated, all specified values are valid for gain setting (gs) 0dB and 1kHz test signal.

gs = 0dB means audio mode = 5, inBbcGain= 0, inCalibrate = 32767, outBbcGain = 0, OutCalibrate = 16384, sideTone = 0.

The electrical characteristics of the voiceband part depend on the current audio mode selected by the AT command AT^SNFS. See Table 9: Audio modes.

The audio modes 4 and 5 can be adjusted by parameters. Each audio mode is assigned a separate parameter set.

⁷ At least one of the following conditions has to be met in order to exceed U_{imax} = 0.6 Vpp up to the restricted voltage limit U_{ires} = 1.6Vpp:
 - A call is established
 - The module is not in power down and the AT command "AT^SNFM=,1" was executed.
 If 0.6Vpp is exceeded under any other condition undervoltage shutdown may be caused.

5.6.1 Audio Parameters Adjustable by AT Commands

Table 30: Audio Parameters Adjustable by AT Commands

Parameter	Influence to	Range	Gain range	Calculation
inBbcGain	MICP/MICN analog amplifier gain of baseband controller before ADC	0...7	0...42dB	6dB steps
inCalibrate	digital attenuation of input signal after ADC	0...32767	$-\infty$...0dB	$20 * \log(\text{inCalibrate}/32768)$
outBbcGain	EPP/EPN analog output gain of baseband controller after DAC	0...3	0...-18dB	6dB steps
outCalibrate[n] n = 0...4	Digital attenuation of output signal after speech decoder, before summation of sidetone and DAC present for each volume step[n]	0...32767	$-\infty$...+6dB	$20 * \log(2 * \text{outCalibrate}[n]/32768)$
sideTone	Digital attenuation of sidetone is corrected internally by outBbcGain to obtain a constant sidetone independently to output volume	0...32767	$-\infty$...0dB	$20 * \log(\text{sideTone}/32768)$

Note: The parameters inCalibrate, outCalibrate and sideTone accept also values from 32768 to 65535, but these values are internally truncated to 32767.

5.7 Characteristics of the GPIOs

Table 31: Characteristics of the GPIOs

Function	Signal name	IO	Signal form and level	Comment
General Purpose Input/Output	GPIO1	I/O	$R_O \approx 100\Omega$ $V_{OLmax} = 0.4V$ at $I = 2mA$ $V_{OHmin} = 2.50V$ at $I = -0.5mA$ $V_{OHmax} = 3.05V$ $V_{ILmax} = 0.8V$ $V_{IHmin} = 2.0V$ $V_{IHmax} = 3.05V$	If unused keep pins with a pull up or pull down resistor while the GPIO is set to input. Alternatively GPIO10 can be used as pulse counter.
	GPIO2	I/O		
	GPIO3	I/O		
	GPIO4	I/O		
	GPIO5	I/O		
	GPIO6	I/O		
	GPIO7	I/O		
	GPIO8	I/O		
	GPIO9	I/O		
	GPIO10	I/O		

5.8 Characteristics of the Pulse Counter

Table 32: Characteristics of the pulse counter

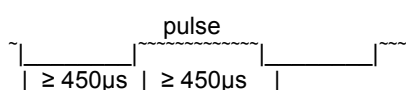
Function	Signal name	IO	Signal form and level	Comment
Pulse Counter	GPIO10	I	$V_{ILmax} = 0.8V$ $V_{IHmin} = 2.0V$ $V_{IHmax} = 3.05V$  slew rate $\leq 1\mu s$	Counter range = 0 ... 1000 pulses per second

5.9 Characteristics of the I²C interface

Table 33: Characteristics of the I²C interface

Function	Signal name	IO	Signal form and level	Comment
I ² C interface	I2CCLK_SPICLK	O	$R_O \approx 33\Omega$ $V_{OLmax} = 0.25V$ at $I = 2mA$ $V_{OHmin} = 2.50V$ at $I = -0.5mA$ $V_{OHmax} = 3.05V$	<p>I2CDAT is configured as Open Drain and needs a pull-up resistor in the host application.</p> <p>According to the I²C Bus Specification Version 2.1 for the fast mode a rise time of max. 300ns is permitted. There is also a maximum $V_{OL}=0.4V$ at 3mA specified.</p>
	I2CDAT_SPIDO	I/O	$R_O \approx 33\Omega$ $V_{OLmax} = 0.25V$ at $I = 2mA$ $V_{ILmax} = 0.8V$ $V_{IHmin} = 2.0V$ $V_{IHmax} = 3.05V$	<p>The value of the pull-up depends on the capacitive load of the whole system (I2C Slave + lines). The maximum sink current of I2CDAT and I2CCLK is 4mA.</p> <p>If lines are unused keep pins open.</p>

5.10 Characteristics of the SPI interface

Table 34: Characteristics of the SPI interface

Function	Signal name	IO	Signal form and level	Comment
SPI Serial Peripheral Interface	I2CCLK_SPICLK	O	$R_O \approx 33\Omega$ $V_{OLmax} = 0.25V$ at $I = 2mA$ $V_{OHmin} = 2.50V$ at $I = -0.5mA$ $V_{OHmax} = 3.05V$ $F_{max} = 6.5MHz$ (possible) 1.083 MHz	<p>If the Serial Peripheral Interface is active the I²C interface is not available.</p> <p>If lines are unused keep pins open.</p>
	I2CDAT_SPIDO	O		
	SPICS	O		
	SPIDI	I	(recommended) $V_{ILmax} = 0.8V$ $V_{IHmin} = 2.0V$ $V_{IHmax} = 3.05V$	

5.11 Characteristics of the ADC Interface

Table 35: Characteristics of the ADC interface

Function	Signal name	IO	Signal form and level	Comment
Analog/ Digital Converter balanced input	ADC1_IN_P ADC1_IN_N		Single ended or differential input voltage ADCx_IN_N = GND or negative voltage ADCx_IN_P = positive voltage VI min = 0V VI max = 5V	ADC1_IN and ADC2_IN are balanced lines and multiplexed with an analog switch. Both inputs are filtered by a low pass
	ADC2_IN_P ADC2_IN_N		Ri single ended $\approx 600\text{k}\Omega$ Ri balanced $\approx 1200\text{k}\Omega$ Cut-off-frequency, $f_g = 70\text{Hz}$ Common-mode rejection ratio, CMRR > 50dB Inaccuracy $\pm 1\text{mV}$ Linear error $\pm 1\text{mV}$ Temperature error $\pm 1\text{mV}$ Burst error $\pm 1\text{mV}$	

5.12 Characteristics of the RTC Supply

Table 36: Characteristics of the RTC supply

Function	Signal name	IO	Signal form and level	Comment
RTC backup	BACKUP	I/O	$V_{INmax} = 4.7\text{V}$ Module power down $V_{INmin} = 2.6\text{V}$ at $I_{max} = 25\mu\text{A}$ Module active $V_{IN} \leq 3.6\text{V}$ $I_{IN} = 0\mu\text{A}$ $V_{IN} \geq 3.7\text{V}$ $I_{IN} = 25\mu\text{A}$	If unused, keep pin open.

5.13 RF Connector

Table 37: RF connector

Parameter	Conditions	Min.	Typical	Max.	Unit
GPRS connectivity	GPRS multislots class 12				
	Time slots Rx			4	
GPRS coding schemes	Time slots Tx			4	
	Full implementation CS-1,CS-2,CS-3, CS-4				
GSM Class	Small MS class B				
Frequency range	EGSM 850	824		894	MHz
	GSM 900	880		1785	MHz
	GSM 1800	1710		1880	MHz
	GSM 1900	1850		1990	MHz
Receiver input Sensitivity @ antenna connector Under all propagation conditions according to GSM Spec.	EGSM 850	-102			dBm
	GSM 900	-102			dBm
	GSM 1800	-102			dBm
	GSM 1900	-102			dBm
Receiver input Sensitivity @ antenna connector BER Class II<=2.43% @ static input level (no fading)	EGSM 850	-102	-105		dBm
	GSM 900	-102	-105		dBm
	GSM 1800	-102	-105		dBm
	GSM 1900	-102	-105		dBm
RF power @ antenna connector (50Ω Load) Under normal conditions (3GPP-Specification)	EGSM 850		31,9		dBm
	GSM 900		31,9		dBm
	GSM 1800		29,2		dBm
	GSM 1900		29,2		dBm

6 Full Type Approval

6.1 Siemens Reference Setup

The Siemens reference setup submitted to type approve TC65 Terminal consists of the following components:

- TC65 Terminal with approved GSM module TC65
- Votronic Handset type
- PC as MMI
- Power Supply: Mains adapter Sphere Design Type 39020
- IO interface connector cable with pull down resistors. Please note that this cable is not available for customer.

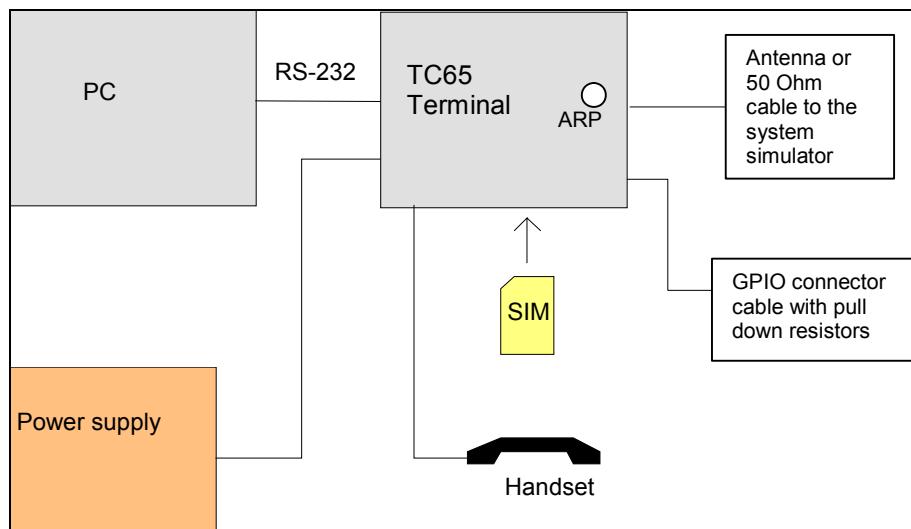

Figure 19: Reference equipment for approval

For ordering information please refer to Chapter 7.

6.2 Compliance with FCC Rules and Regulations

As an integrated product, the TC65 Terminal is fully compliant with the grant of FCC Equipment Authorization issued for the in-built TC65 Module, and therefore, bears the label “*Contains FCC ID QIPTC65*”.

The FCC Equipment Authorization Certification for the TC65 Module is listed under the
FCC identifier QIPTC65
IC: 267W-TC65
granted to Siemens AG.

The Siemens reference application of the TC65 Module registered under the above identifier is certified to be in accordance with the following Rules and Regulations of the Federal Communications Commission (FCC). Power listed is ERP for Part 22 and EIRP for Part 24.

“This device contains GSM and GPRS Class12 functions in the 900 and 1800MHz Band which are not operational in U.S. Territories. This device is to be used only for mobile and fixed applications. The antenna(s) used for this transmitter must be installed to provide a separation distance of at least 20cm from all persons and must not be co-located or operating in conjunction with any other antenna or transmitter. Users and installers must be provided with antenna installation instructions and transmitter operating conditions for satisfying RF exposure compliance. Antennas used for this OEM module must not exceed 8.4dBi gain (GSM 1900) and 2.9dBi (GSM 850) for mobile and fixed operating configurations. This device is approved as a module to be installed in other devices.”

Please note that changes or modifications not expressly approved by the party responsible for compliance could void the user’s authority to operate the equipment.

6.3 Cable Requirements

The TC65 Terminal has to be tested and approved for use with a maximum cable length of 3m for following interfaces:

- USB interface (shielded)
- Serial interface (RS232)
- ADC inputs
- GPIOs

The length of following lines may exceed 3m:

- DC power supply lines
- Audio interface
- Antenna interface

It is recommended to keep the digital lines for I²C-, SPI- lines as short as possible. The maximum cable length is 150mm.

6.4 Restrictions

Later enhancements and modifications beyond the certified configuration require extra approvals. Each supplementary approval process includes submittal of the technical documentation as well as testing of the changes made.

- No further approvals are required for customer applications that comply with the approved TC65 Terminal configuration.
- Extra approval must be obtained for applications using other accessories than those included in the approved TC65 Terminal configuration (handset, power supply, MMI implementation supported by AT commands).

6.5 CE Conformity

The TC65 Terminal meets the requirements of the EU directives listed below:

- R&TTE Directive 1999/5/EG
- LVD 73/23/EEC
- EMC conformity in accordance with Directive 89/336/EEC

6.6 Electromagnetic Compatibility (EMC)

The TC65 Terminal meets EN 301489-7 requirements of equipment for vehicular and fixed use.

Note: V_{POWER} voltage dip or interruption corresponding to a reduction of the supply voltage of >30% for >1ms does reset or shut down the terminal.

The TC65 Terminal does not resist against test pulse 5 according ISO 7637-2 (load dump at vehicles 24 volt supply voltage). The internal slow acting, not removable fuse will be damaged. It is recommended to use an external fast acting fuse $I \geq 0.8A$ with melting integral I^2t (0.8...1.5) A^2s .

To meet the EN55022 requirements (field strength), the SPI transfer rate has to be set $\leq 1.083Mbps$, otherwise the application shall be designed to meet additional EMC measures.

7 List of Parts and Recommended Accessories

Table 38: List of parts and accessories

Description	Supplier	Ordering information
TC65 Terminal	Siemens	Siemens ordering number: L36880-N8670-B200
Power supply unit Primary adapter (US)	Sphere Design	Ordering number: 39020 Ordering number: 39004 Sphere Design Saarpfalz-Park 17 D-66450 Bexbach / Saar Phone: +49-6826-5200-0 Fax: +49-6826-5200-25 E-Mail: info@spheredesign.de http://www.spheredesign.de
Handset	Votronic	Ordering number: HH-SI-30.3/V1.1/0 Votronic GmbH Saarbrücker Str. 8 D-86386 St. Ingbert Phone: +49-6894-9255-44 Fax: +49-6894-9255-88
Antenna Magnet. Mount US (GSM 850 +GSM 1900) EU (GSM 900 +GSM 1800)	Smarteq Smarteq	MiniMag 1140.27 MiniMag 1140.26 E-Mail: info@smarteq.se http://www.smarteq.com
Direct Mount US (GSM 850 +GSM 1900) EU (GSM 900 +GSM 1800)	Bondale Bondale Radiall	RA-10090(291-066/A) RA-10090(789-014/A) http://www.bondale.com R380.900.307 http://www.radiall.com

Description	Supplier	Ordering information
GPIO-Connector	Tyco Electronics AMP	Ordering Numbers: Mating connector Micro Mate-N_LOK 3mm: 2-794617-4 Crimp Snap_In contacts: 794606-* or 794607-* (24 pieces/housing for full assembly) Hand Tool CERTI-CRIMP II Straight: 91501-1 http://www.tycoelectronics.com/cust.stm
Rail Clip	Firma Richard Wöhr GmbH	Ordering number: Hutscclip/AL/0002 Richard Wöhr GmbH Gräfenau 58-60 D-75339 Höfen/Enz Phone: +49-7081-9540-0 Fax: +49-7081-9540-90 E-Mail: info-ig@woehrgmbh.de http://www.industriegehaeuse.woehrgmbh.de
Screws for Rail Clip	EJOT GmbH & Co. KG	Ordering number: EJOT Delta PT Screw WN5454,40x11-S http://www.ejot.de